

承 認 書

APPROVAL SHEET

承認字號： 32HA257
Approval No. _____

客戶/廠商： 新巨 ZIPPY
Customer/Vender _____

成品/零組件： PSU,
Product Component _____

規格： REDUNDANT,1+1,620W,C2W-5620V,EPS12V,W/PFC,FULL
Specification RANGE,P24:700MM,P4+P4:610MM,P8:600MM,W/PMBUS,ZIPPY,RM23424e15

料號： 32H2062000202
Part No. _____

<p>客戶核准 Customer Approval</p>	<p>最後判定 Final Approval</p>
	<div style="border: 2px solid blue; padding: 10px; text-align: center;"> <p>CHENBRO DCC 文管中心</p> <hr/> <p>AUG.26.2010</p> <hr/> <p>APPROVAL 核准</p> </div>

REVISIONS			
REV	DESCRIPTION	DATE	MODIFIED BY
△			

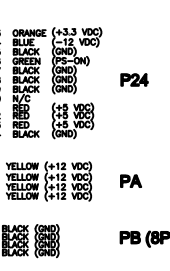
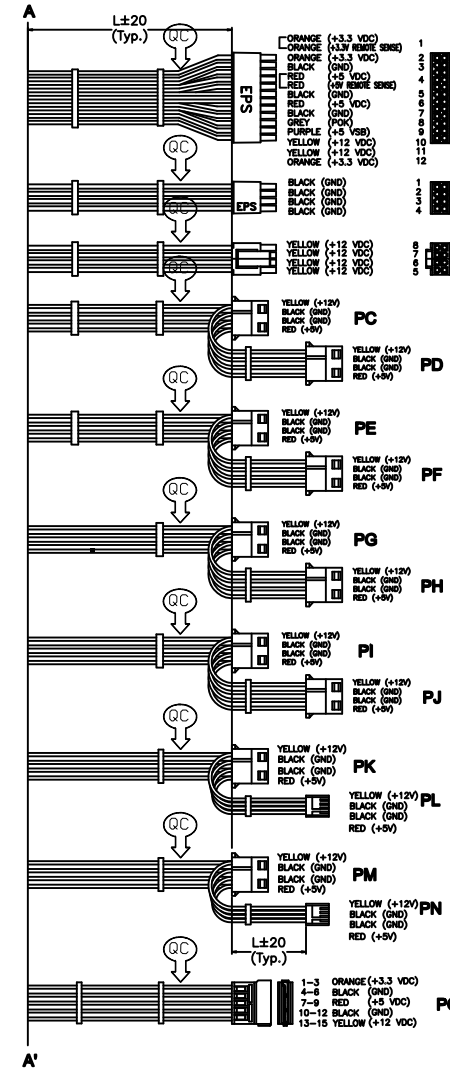
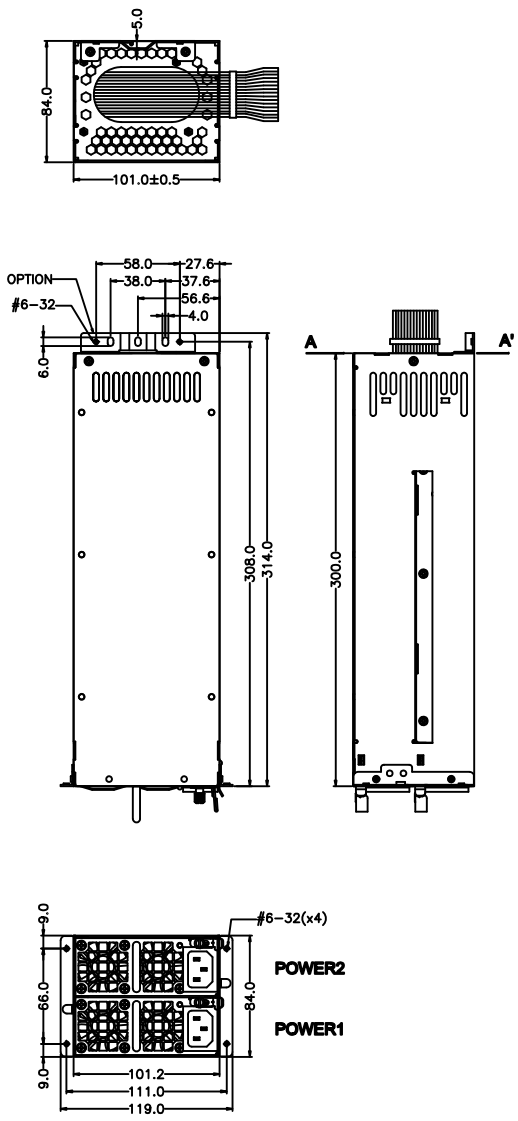

WIRE LENGTH LIST

HOUSING	LENGTH
P24	700
PA	600
PB	610
PC	450
PD	150
PE	450
PF	150
PG	300
PH	150
PI	300
PJ	150
PK	400
PL	150
PM	300
PN	150
PO	650
TTL SIGNAL	670
BUZZER RESET	660
PMBus	670

TOLERANCES: ±20
UNIT: mm

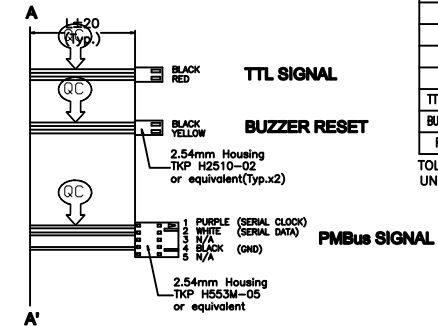

- Notes:**
- (a) All the Length of Output Wires Exclude Housing.
 - (b) P24 Connector: MOLEX 39-01-2240 or EQUIV. Terminal: MOLEX 39-00-0059 or EQUIV.
 - (c) PA Connector: MOLEX 39-01-2080 or EQUIV. Terminal: MOLEX 39-00-0059 or EQUIV.
 - (d) PB Connector: WST P8-H2002K3 or EQUIV. Terminal: MOLEX 39-00-0059 or EQUIV.
 - (e) PC-PK,PM Connector: AMP 1-480424-0 or EQUIV. Terminal: AMP 61117-4 or EQUIV.
 - (f) PL,PN Connector: AMP 171822-4 or EQUIV. Terminal: AMP 170262-1 or EQUIV.
 - (g) PO Connector: MOLEX 676820000 or EQUIV. Terminal: MOLEX 676810000 or EQUIV.

勤誠興業股份有限公司
CHENBRO MICOM CO., LTD
DCC 文管中心
AUG.20.2010
RELEASE 發行

Part No:32H2062000202
RoHS Compliance
ZIPPY C2W-5620V

CHENBRO			MATERIAL SPEC.	UNSPECIFIED TOL'S	MODEL NO:
			-----	X.XX ±0.1 XX.XX ±0.2 XXX.XX ±0.2 ANGULAR ±0.5°	RM23424
APPROVED BY	Jounghwa	2010/08/20	UNIT	TITLE	
			mm	ZIPPY C2W-5620V 620W 1+1 PSU	
CHECKED BY	-----	-----	SCALE	DRAWING NO.	REV.
DESIGN BY	Max Cheng	2010/08/18			
					SHEET
					1/1

承認書

SPECIFICATION FOR APPROVAL

客戶

CUSTOMER：勤誠興業股份有限公司

品名

STYLE NAME：SWITCHING REDUNDANT POWER SUPPLY

型號

MODEL NO.：C2W-5620V(ROHS)

料號

PART NO.：B00C2W062V001(32H2062000202)B2

客戶認可 APPROVED BY	
認可日期 APPROVED DATE	

APPROVE 核准	黃永欣
CHECK BY 審核	李崇德
FORM MAKER 經辦	黃碧霞 99.08.19

新巨企業股份有限公司
電源事業處
ZIPPY TECHNOLOGY CORP.
POWER DIVISION

2F,NO.50 MIN CHYUAN RD.,
SHIN-TIEN CITY,TAIPEI HSIEN,
TAIWAN,R.O.C.
TEL.：+886(2)29188512
FAX.：+886(2)9134969



版次 REV.	修訂 REVISIONS	日期 DATE
B2	變更線材 DESCRIPTION	MAR-092010



HOUSING	LENGTH
P24	700
PA	600
PB	610
PC	450
PD	150
PE	450
PF	150
PG	300
PH	150
PJ	150
PK	400
PL	150
PM	300
PN	150
PO	650
TTL SIGNAL	670
BUZZER RESET	660
PMBus	670

TOLERANCES: ±20
UNIT: mm

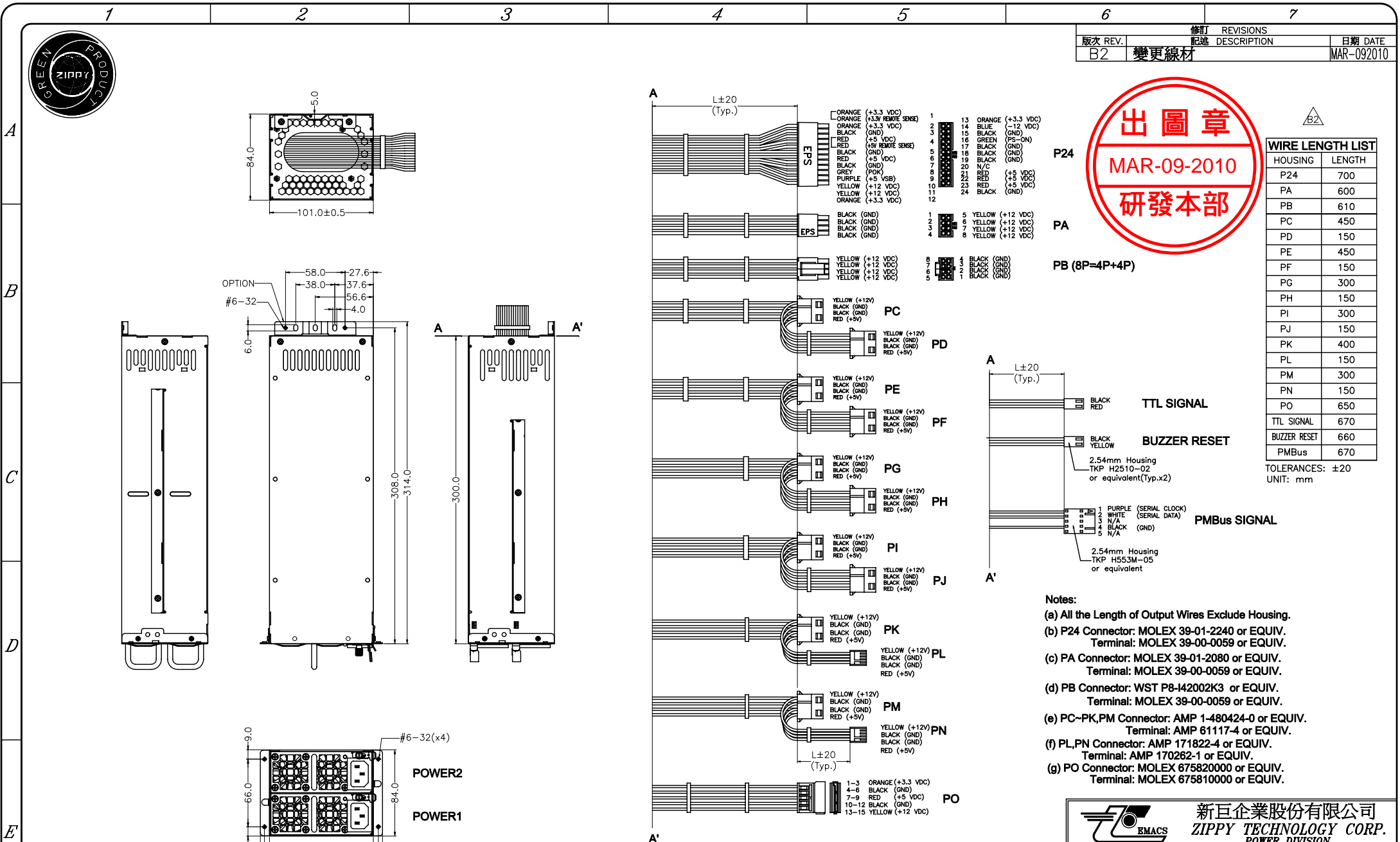

A
B
C
D
E

- Notes:**
- (a) All the Length of Output Wires Exclude Housing.
 - (b) P24 Connector: MOLEX 39-01-2240 or EQUIV. Terminal: MOLEX 39-00-0059 or EQUIV.
 - (c) PA Connector: MOLEX 39-01-2080 or EQUIV. Terminal: MOLEX 39-00-0059 or EQUIV.
 - (d) PB Connector: WST P8-I42002K3 or EQUIV. Terminal: MOLEX 39-00-0059 or EQUIV.
 - (e) PC~PK, PM Connector: AMP 1-480424-0 or EQUIV. Terminal: AMP 61117-4 or EQUIV.
 - (f) PL, PN Connector: AMP 171822-4 or EQUIV. Terminal: AMP 170262-1 or EQUIV.
 - (g) PO Connector: MOLEX 675820000 or EQUIV. Terminal: MOLEX 675810000 or EQUIV.

容許公差: TOLERANCES:	.XXX ±.025 .XX ±.100 .X ±.250
投影法: PROJECTION:	第三角法

材料規格: MATERIAL:	核准者: APPROVE BY:	日期: DATE:
審核者: CHECK BY:	日期: DATE:	日期: DATE:
繪圖者: DRAW BY:	日期: DATE:	日期: DATE:

新巨企業股份有限公司 ZIPPY TECHNOLOGY CORP. POWER DIVISION	
品名: MODEL NO:	C2W-5620V
料號: PART NO:	B00C2W062V001
圖號: DRAW NO:	B00C2W062V001
槽號: FILE NO:	B00C2W062V001
單位: UNITS:	mm
版次: REV. NO:	B2
規格: SPEC:	A0
編號: SHEET:	OF

版次 REV.	修訂 REVISIONS 配碼 DESCRIPTION	日期 DATE
A2	將圓孔修改為橢圓孔	SEP-02-2002

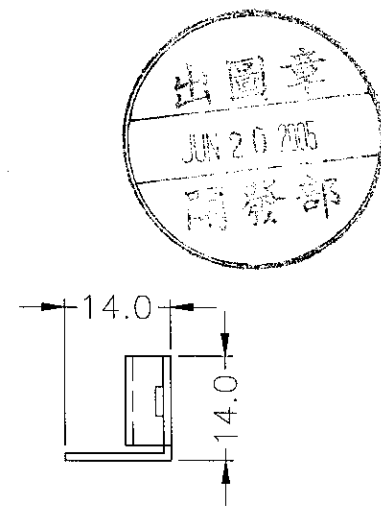
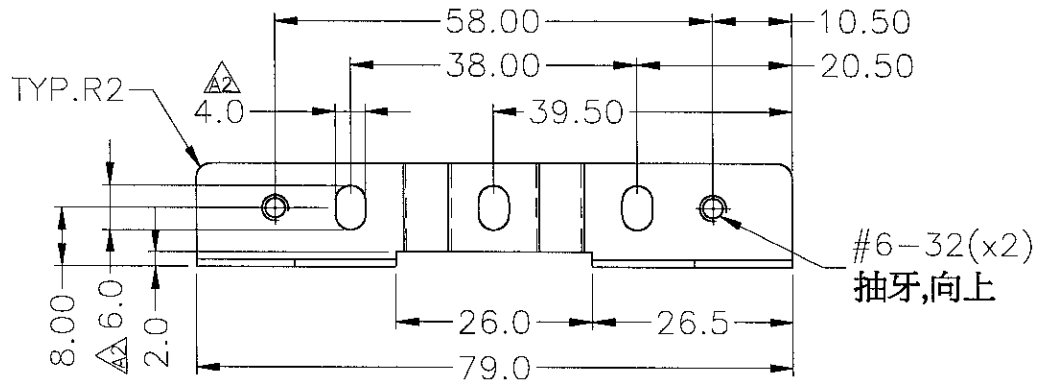
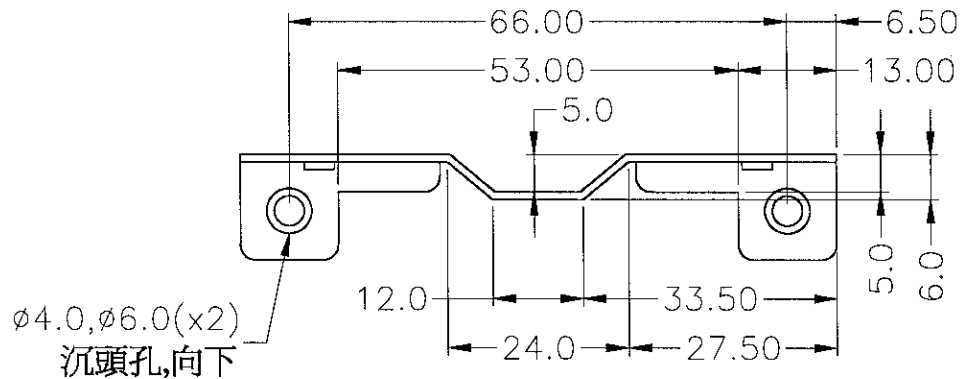

B300050094_B1
2300050100

容許公差: TOLERANCES:	材料規格: MATERIAL:	品名: MODEL NO:
.XXX ±.025	SPCC T=1.0mm 鍍鎳	R2G 固定架 2
.XX ±.100	核准者: APPROVE BY:	料號: PART NO:
.X ±.250	黃永欣	245-10157
日期: DATE:	審核者: CHECK BY:	圖號: DRAW NO:
	李宗翰	R2G0MS11
日期: DATE:	繪圖者: DRAW BY:	規格: SPEC:
SEP-02-2002		A4
單位: UNITS:	版次: REV. NO:	編號: SHEET:
mm	A2	OF

新巨企業股份有限公司
ZIPPY TECHNOLOGY CORP.
POWER DIVISION

品名：薄皿⊕6#x4 UNC

料號：B300000046

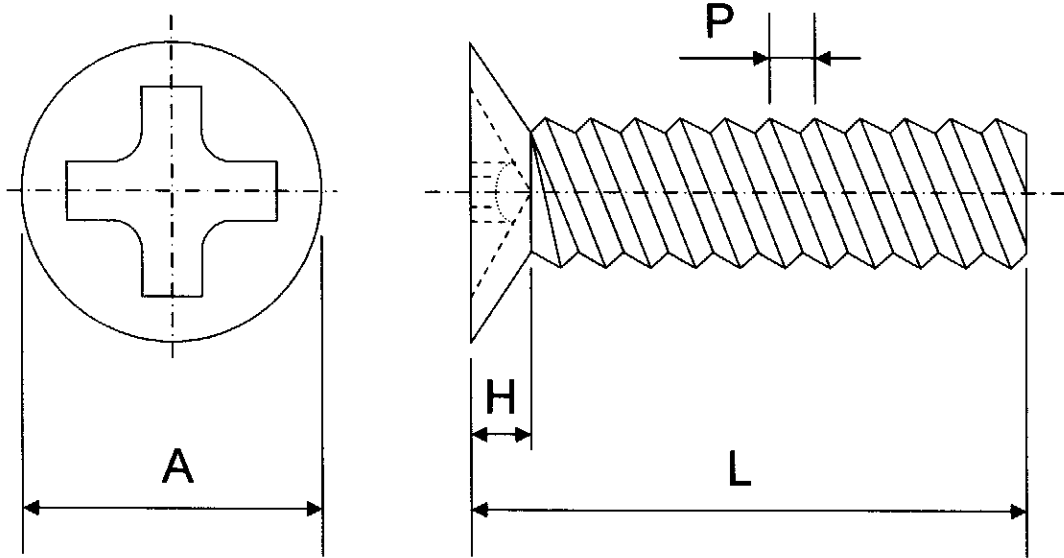

	A	H	L	P	處理
規格	5.1±0.2	1.2±0.2	4.0+0.1,-0.3	6#-32	鎳
第1次測	5.13	1.08	4.01	6#-32	鎳
第2次測	5.12	1.06	4.02	6#-32	鎳
第3次測	5.14	1.09	4.01	6#-32	鎳
第4次測	5.13	1.05	4.03	6#-32	鎳
第5次測	5.15	1.08	4.00	6#-32	鎳



同利螺絲企業有限公司
Tung-Li Screw Enterprise Co.,LTD

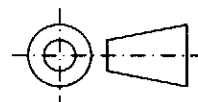

規格書



SPECIFICATION

品名 REDUNDANT SWITCHING POWER SUPPLY
 STYLE NAME :

型號 C2W-5620V
 MODEL NO. :

料號
 PART NO. :

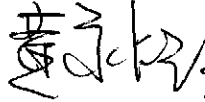
版次 A1
 REVISION :

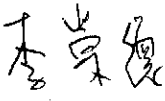
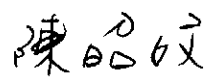
APPROVE 核准	 JAN. 04, 2010	正式資料 用章	
CHECK BY 審核	 JAN. 04, 2010		
FORM MAKER 經辦	 JAN. 04, 2010		

新巨企業股份有限公司
 電源事業處
 ZIPPY TECHNOLOGY CORP.
 POWER DIVISION

10F, NO. 50 MIN CHYUAN RD.,
 SHIN-TIEN CITY, TAIPEI HSIEN,
 TAIWAN, R.O.C.
 TEL. : +886(2)29188512
 FAX. : +886(2)29134969

Revision

Rev.	Page	Item	Date	Description

MODEL NO. C2W-5620V

- 1.0 Scope
- 2.0 Input requirements
 - 2.1 Voltage
 - 2.2 Frequency
 - 2.3 Steady-state current
 - 2.4 Inrush current
 - 2.5 Power factor correction
- 3.0 Output requirements
 - 3.1 DC load requirements
 - 3.2 Regulation
 - 3.3 Ripple and noise
 - 3.3.1 Specification
 - 3.3.2 Ripple voltage test circuit
 - 3.4 Overshoot
 - 3.5 Efficiency
 - 3.6 Remote on/off control
- 4.0 Protection
 - 4.1 Input
 - 4.2 Output
 - 4.2.1 OPP
 - 4.2.2 OVP
 - 4.2.3 Short current
 - 4.2.4 OCP
- 5.0 Power supply sequencing
 - 5.1 Turn on
 - 5.2 Hold up time
 - 5.3 Power off sequence
- 6.0 Signal requirements
 - 6.1 Power good signal
 - 6.2 Under voltage sense level
- 7.0 Environment
 - 7.1 Temperature
 - 7.2 Humidity
 - 7.3 Insulation resistance
 - 7.4 Dielectric withstanding voltage
 - 7.5 Leakage current

8.0 Safety

8.1 UL & UL+C

8.2 TUV

8.3 CB

9.0 Reliability

9.1 Burn in

10.0 Mechanical requirements

11.0 Warning method

11.1 Audio alarm

11.2 Fault LED

11.3 Power defective signal delivery

12.0 DC output cable drawing

13.0 Output voltage Timing

1.0 Scope

This specification defines the performance characteristics of a grounded , single-phase , 620 watts , 5 output level power supply. This specification also defines world wide safety requirements and manufactures process test requirements. C2W-5620V power system is a 1+1 Redundant power system consisting of two C2W-5620V-R power modules and one C2W-5620V power system frame.

2.0 Input requirements

2.1 Voltage (sinusoidal)

Full range 100~240 VAC

2.2 Frequency

The input frequency range will be 50Hz/60Hz(±3Hz).

2.3 Steady-state current(Power module)

8.0 – 4.0 amps maximum at any low/high range input voltage.

2.4 Inrush current(Power module)

35 / 70 amps @115/230 VAC (at 25 degrees ambient cold start for each power unit)

2.5 Power factor correction

The power supply modules shall incorporate universal power input with active power factor correction, which shall reduce line harmonics in accordance with the EN 61000-3-2 standards.

PFC can reach the target of 95% @230V,full load.

3.0 Output requirements

3.1 DC load requirements

Normal Output voltage	Load current		Regulation tolerance	
	Max.1+1	Min 1+1	Max.	Min.
+5V	25.0	0.5	+5%	-5%
+12V	50.0	2.0	+5%	-5%
-12V	0.8	0	+10%	-10%
+3.3V	25.0	0.5	+5%	-5%
+5VSB	3.5	0	+5%	-5%

*** +5V and +3.3V total output max : 170W ***

*** Total output max : 620W ***

When doing the cross regulation test(one output channel at high load and the other output channels at low load), it is requested to set the higher output channel at 80% max. of its spec., and the lower output channels at 20% max. of theirs.

3.2 Regulation

Output DC voltage	Line regulation
+5V	±50mV
+12V	±120mV
-12V	±120mV
+3.3V	±50mV
+5VSB	±50mV

3.3 Ripple and noise

3.3.1 Specification

+5V	50mV (P-P)
+12V	120mV (P-P)
-12V	120mV (P-P)
+3.3V	50mV (P-P)
+5VSB	50mV (P-P)

3.3.2 Ripple voltage test circuit

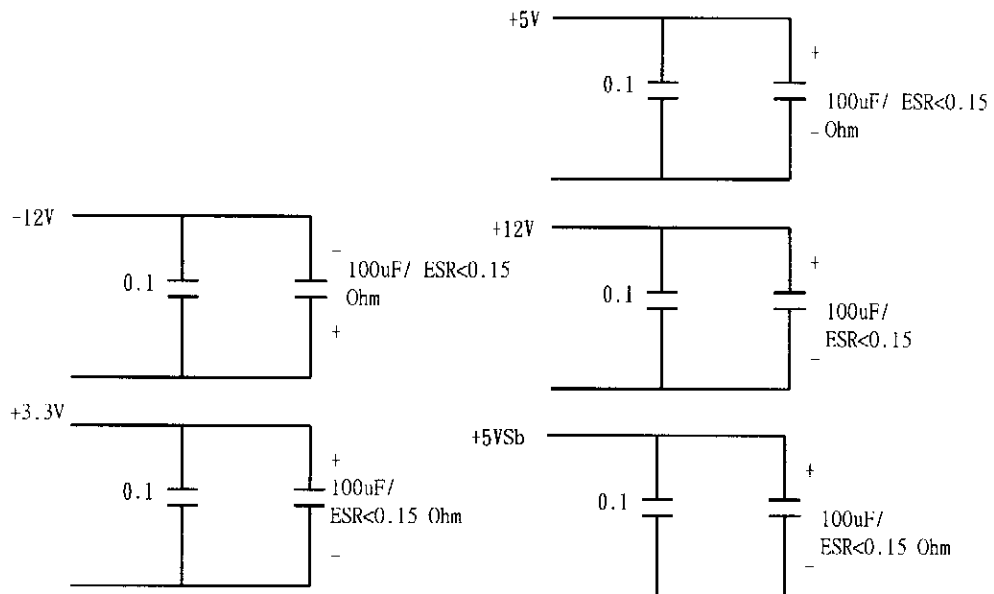

0.1µf is ceramic, the other is electrolytic capacitor.

Noise bandwidth is from DC to 20Mhz

3.4 Overshoot

Any overshoot at turn on or turn off shall be less than 10% of the nominal voltage value , all output shall be within the regulation limit of section 3.1 before issuing the power good signal of section 6.0.

3.5 Efficiency

Power supply efficiency typical >80% at 230V full load.

P.S:

Any difference either on the DC output cable (i.e., length, wire gauge) or on the accurate of instruments will conclude different test result.

3.6 Remote on/off control

The power supply DC outputs (with the exception of +5VSB) shall be enabled with an active-low , TTL-compatible signal("PS-ON")

When PS-ON is pulled to TTL low , the DC outputs are to be enabled.

When PS-ON is pulled to TTL high or open circuited , the DC outputs are to be disabled. TTL is compatible high level (2.4V to 5.25V) and low level (0.0V to 0.8V)

4.0 Protection

4.1 Input (primary)

The input power line must have an over power protection device in accordance with safety requirement of section 8.0

4.2 Output (secondary)

4.2.1 Over power protection (one unit)

The power supply shall provide over power protection on the power supply latches all DC output into a shutdown state. Over power of this type shall cause no damage to power supply , after over load is removed and a power on/off cycle is initiated , the power supply will restart.

Trip point total power min. 110% , max. 160%.

4.2.2 Over voltage protection

If an over voltage fault occurs , the power supply will latch all DC output into a shutdown state before

+5V : 5.9V ~ 6.7V

+3.3V : 3.9V ~ 4.3V

+12V : 13.0V ~ 15.0V

4.2.3 Short circuit

A: A short circuit placed on any DC output to DC return shall cause no damage.

B: The power supply shall be latched in case any short circuit is taken place at +5V,+3.3V,+12V,-12V output.

C: The power supply shall be auto-recovered in case any short circuit is taken place at +5VSB.

4.2.4 Over current protection

If an over current fault occurs , the power supply will latch all DC output into a shutdown state.

	Min	Typical	Max
+3.3V	27.5A	32.5A	37.5A
+5V	27.5A	32.5A	37.5A
+12V	55A	65A	80A

5.0 Power supply sequencing

5.1 Power on (see fig.1)

5.2 Hold up time

When power shutdown DC output 5V must be maintain 16msec in regulation limit at normal input voltage.

5.3 Power off sequence (see fig. 1)

6.0 Signal requirements

6.1 Power good signal (see fig. 1)

The power supply shall provide a "power good" signal to reset system logic , indicate proper operation of the power supply , and give advance warning of impending loss of regulation at turn off. This signal shall be a TTL compatible up level (2.4V to 5.25V) when +5V output voltage are present and above the minimum UV sense levels specified in paragraph 6.2 , or a down level (0.0V to 0.8V) when any output is below its minimum UV sense level.

At power on , the power good signal shall have a turn on delay of at least 100ms but not greater than 500ms after the output voltages have reached their respective minimum sense levels.

6.2 Under voltage (UV) sense levels

Output	Minimum sense voltage
+5V	+4.50V
+3.3V	+2.50V

7.0 Environment

7.1 Temperature

Operating temperature	0 to 40 degrees centigrade
Non-Operating temperature	-20 to 80 degrees centigrade

7.2 Humidity

Operating humidity	20% to 80%
Non-operating humidity	10% to 90%

7.3 Insulation resistance

Primary to secondary	: 100 meg. ohm min. 500 VDC
Primary to Frame Gnd	: 100 meg. ohm min. 500 VDC

7.4 Dielectric withstanding voltage

For approval purpose :

Primary to secondary : 3KVAC for 1min.
Primary to Frame Gnd : 1500 VAC for 1 min.

For production purpose: 100% test

Primary to Frame Gnd : 1500VAC for 1 sec
Cut off current 15mA

7.5 Leakage current

3.5 mA. max. at nominal voltage 250 VAC

8.0 Safety

8.1 Recognized to U.S. and Canadian requirements under the component recognition program of Underwriters Laboratories Inc.
The power supply shall be designed to meet UL60950.

8.2 TUV Standards

The power supply shall be designed to meet TUV EN-60950.

8.3 CB

The power supply shall be designed to meet CB IEC 60950.

9.0 Reliability

9.1 Burn in

All products shipped to customer must be processed by burn-in. The burn- in shall be performed for 1 hour at full load.

10.0 Mechanical requirements

Physical dimension : 300 mm * 101 mm * 84 mm (D *W* H)

11.0 Warning method

- 11.1 Audio alarm(buzzer sound,resetable)
- 11.2 Fault LED
- 11.3 Power defective signal delivery(TTL,Lowactive)

12.0 Output power derating characteristics

Output Power Derating Characteristics

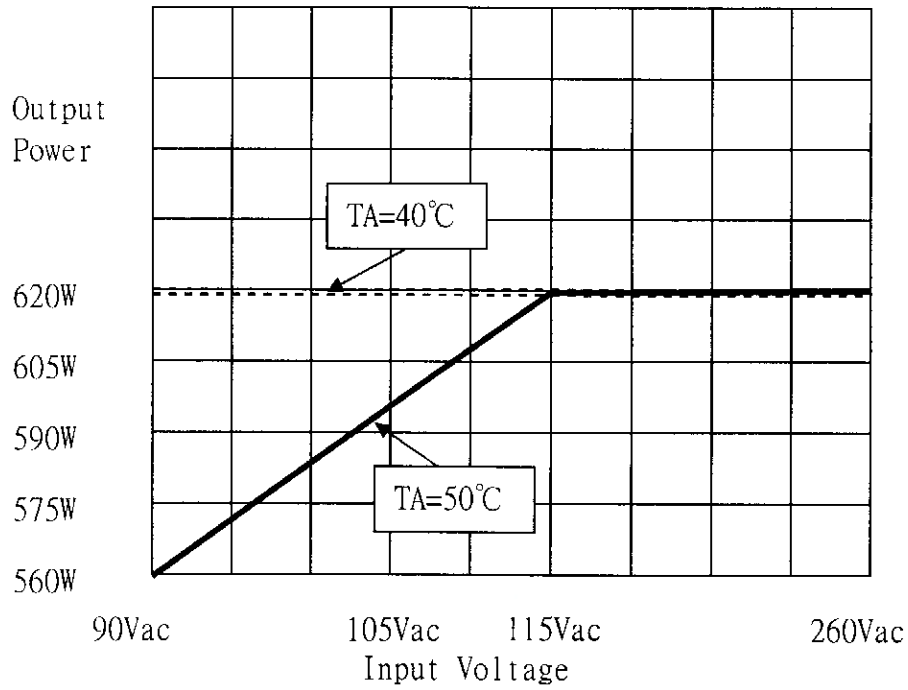

13.0 Output voltage Timing

Item	Description	MIN	MAX	UNITS
Tsb_on_delay	Delay from AC being applied to 5VSB being within regulation.		1500	ms
Tac_on_delay	Delay from AC being applied to all output voltages being within regulation.		2500	ms
Tvout_holdup	Time all output voltages stay within regulation after loss of AC.	16		ms
Tpwok_holdup	Delay from loss of AC to deassertion of PWOK.	15		ms
Tpson_on_delay	Delay from PSON# active to output voltages within regulation limits.	5	400	ms
Tpson_pwok	Delay from PSON# deactive to PWOK being deasserted.		50	ms
Tpwok_on	Delay from output voltages within regulation limits to PWOK asserted at turn on.	100	500	ms
Tpwok_off	Delay from PWOK deasserted to output voltages (3.3V, 5V, 12V, -12V) dropping out of regulation limits.	1		ms
Tsb_vout	Delay from 5VSB being in regulation to O/Ps being in regulation at AC turn on.	5	1000	ms
Tsb_holdup	Time 5VSB output voltage stays within regulation after loss of AC.	70		ms
Tvout_rise	Output voltage rise time from each main output.	5	20	ms

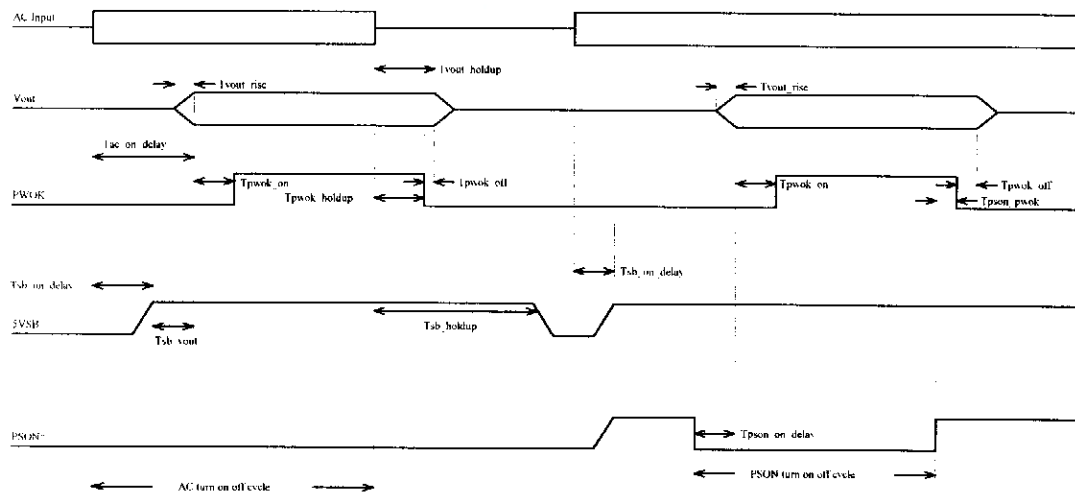

Fig.1

COVER PAGE FOR TEST REPORT

Product Category:	Power Supplies for Information Technology Equipment Including Electrical Business Equipment
Product Category CCN:	QQGQ2, QQGQ8
Test Procedure:	Component Recognition
Product:	Redundant Power Supply and Power Module
Model/Type Reference:	Redundant Power Supply: C2W-5620V, C2W-5820V, C2W-5A50V. Power Module: C2W-3620V-R, C2W-3820V-R, C2W-3A50V-R.
Rating(s):	See Enclosure Miscellaneous Id. 7-01
Standards:	UL 60950-1, 2nd Edition, 2007-03-27 (Information Technology Equipment - Safety - Part 1: General Requirements) CSA C22.2 No. 60950-1-07, 2nd Edition, 2007-03 (Information Technology Equipment - Safety - Part 1: General Requirements)
Applicant Name and Address:	ZIPPY TECHNOLOGY CORP 10TH FL 50 MIN CHYUAN RD SHIN-TIEN TAIPEI HSIEN 231 TAIWAN
This Report includes the following parts, in addition to this cover page:	
<ol style="list-style-type: none">1. Specific Inspection Criteria2. Specific Technical Criteria3. Clause Verdicts4. Critical Components5. Test Results6. National Differences7. Enclosures	

This is to certify that representative samples of the products covered by this Test Report have been investigated in accordance with the above referenced Standards. The products have been found to comply with the requirements covering the category and the products are judged to be eligible for Follow-Up Service under the indicated Test Procedure. The manufacturer is authorized to use the UL Mark on such products which comply with this Test Report and any other applicable requirements of Underwriters Laboratories Inc. ('UL') in accordance with the Follow-Up Service Agreement. Only those products which properly bear the UL Mark are considered as being covered by UL's Follow-Up Service under the indicated Test Procedure.

The applicant is authorized to reproduce the referenced Test Report provided it is reproduced in its entirety.

UL authorizes the applicant to reproduce the latest pages of the referenced Test Report consisting of the first page of the Specific Technical Criteria through to the end of the Conditions of Acceptability.

Any information and documentation provided to you involving UL Mark services are provided on behalf of Underwriters Laboratories Inc(ULI) or any authorized license of ULI.

Test Report By:



Terence She
Associate Project Engineer
Underwriters Laboratories Taiwan Co., Ltd.

Reviewed By:



Jonathan Chen
Associate Project Engineer
Underwriters Laboratories Taiwan Co., Ltd.

IEC**IECEE
CB
SCHEME**

Ref. Certif. No.

JPTUV-031298

IEC SYSTEM FOR MUTUAL RECOGNITION OF TEST
CERTIFICATES FOR ELECTRICAL EQUIPMENT
(IECEE) CB SCHEMESYSTEME CEI D'ACCEPTATION MUTUELLE DE
CERTIFICATS D'ESSAIS DES EQUIPEMENTS
ELECTRIQUES (IECEE) METHODE OC**CB TEST CERTIFICATE
CERTIFICAT D'ESSAI OC**Product
Produit

Redundant Power Supply and Power Module

Name and address of the applicant
Nom et adresse du demandeurZippy Technology Corp.
10F., No. 50, Min Chyuan Rd.
Shin Tien City, Taipei 231 TaiwanName and address of the manufacturer
Nom et adresse du fabricantZippy Technology Corp.
10F., No. 50, Min Chyuan Rd.
Shin Tien City, Taipei 231 TaiwanName and address of the factory
Nom et adresse de l'usineZippy Technology Corp.
2F., No. 123, Lane 235
Pao-Chiao Rd., Shin Tien City, Taipei Hsien 231 TaiwanRating and principal characteristics
Valeurs nominales et caractéristiques principalesInput : AC 100-240V; 47-63Hz; 10-5A(b=620) or
13-6.5A(b=820) or 15-7A; AC 200-240V; 47-63Hz; 7.5A
(for C2W-5A50V, C2W-3A50V-R only); Class I
Output: refer to the test report

EMACS

Trade mark (if any)
Marque de fabrique (si elle existe)Redundant Power Supply: C2W-5A50V, C2W-5bV (b= 620 or 820)
Power Module: C2W-3A50V-R, C2W-3bV-R (b= 620 or 820)Model/type Ref.
Ref. de type

For model differences, refer to the test report.

Additional information (if necessary)
Information complémentaire (si nécessaire)A sample of the product was tested and found
to be in conformity with
Un échantillon de ce produit a été essayé et a été
considéré conforme à laIEC 60950-1:2005
National differences see test reportAs shown in the Test Report Ref. No. which forms part
of this Certificate
Comme indiqué dans le Rapport d'essais numéro de
référence qui constitue une partie de ce Certificat

11019623 001

This CB Test Certificate is issued by the National Certification Body
Ce Certificat d'essai OC est établi par l'Organisme National de CertificationTÜV Rheinland Japan Ltd.
Global Technology Assessment Center
4-25-2 Kita-Yamata, Tsuzuki-ku
Yokohama 224-0021 Japan
Phone + 81 45 914-3888
Fax + 81 45 914-3354
Mail: info@jpn.tuv.com
Web: www.tuv.com

Date: 17.03.2010

Signature:

Dipl.-Ing. W. Hsu

Zertifikat

Certificate



Zertifikat Nr. *Certificate No.*
R 50177272

Blatt *Page*
0001

Ihr Zeichen <i>Client Reference</i>	Unser Zeichen <i>Our Reference</i>	Ausstellungsdatum	<i>Date of Issue</i> (day/month/year)
EH/SPC-1002041-spc	ZTW1-HCR- 10028417 001	18.03.2010	

Genehmigungsinhaber *License Holder*
Zippy Technology Corp.
10F., No. 50, Min Chyuan Rd.
Shin Tien City, Taipei 231
Taiwan

Fertigungsstätte *Manufacturing Plant*
Zippy Technology Corp.
2F, No. 123, Lane 235
Pao-Chiao Rd.
Shin Tien City, Taipei Hsien 231
Taiwan

Prüfzeichen *Test Mark*

Geprüft nach *Tested acc. to*
EN 60950-1:2006+A11

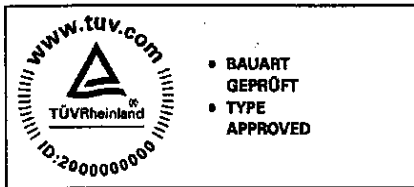

Zertifiziertes Produkt (Geräteidentifikation)
Certified Product (Product Identification)

Lizenzentgelte - Einheit
License Fee - Unit

Einbau-Schaltnetzteil (Redundant Power Supply and Power Module)

Bezeichnung (Type Designation)	: C2W-5A50V (EMACS)	10
Nennspannung (Rated Voltage)	: 1) AC 100-240V, 47-63Hz 2) AC 200-240V, 47-63Hz	
Nennstrom (Rated Current)	: 1) 15-7A 2) 7.5A	
max. Umgebungstemperatur (max. Ambient Temperature)	: 45°C	
max. Betriebshöhe (max. Operating Altitude)	: 3100m	
Schutzklasse (Protection Class)	: I	
Verschmutzungsgrad (Pollution Degree)	: 2	



Fortsetzung Blatt (continued on page) 02

10

ANLAGE (Appendix): 1

Dem Zertifikat liegt unsere Prüf- und Zertifizierungsordnung zugrunde und es bestätigt die Konformität des Produktes mit den oben genannten Standards und Prüfgrundlagen. Zusätzliche Anforderungen in Ländern, in denen das Produkt in Verkehr gebracht werden soll, müssen zusätzlich betrachtet werden. Die Herstellung des zertifizierten Produktes wird überwacht.
This certificate is based on our Testing and Certification Regulation and states the conformity of the product with the standards and testing requirements as indicated above. Any additional requirements in countries where the product is going to be marketed have to be considered additionally. The manufacturing of the certified product is subject to surveillance.

Zertifizierungsstelle

TÜV Rheinland LGA Products GmbH - Tillystraße 2 - 90431 Nürnberg
Tel.: (+49/221)8 06 - 13 71 e-mail: cert-validity@de.tuv.com
Fax: (+49/221)8 06 - 39 35 http://www.tuv.com/safety

Dipl.-Ing. F. Stöelzel

Zertifikat

Certificate



Zertifikat Nr. *Certificate No.* Blatt *Page*
R 50177272 0002

<i>Ihr Zeichen Client Reference</i>	<i>Unser Zeichen Our Reference</i>	<i>Ausstellungsdatum</i>	<i>Date of Issue</i> <i>(day/mo/yr)</i>
EH/SPC-1002041-spc	ZTW1-HCR- 10028417 001	18.03.2010	

Genehmigungsinhaber *License Holder*

Zippy Technology Corp.
10F., No. 50, Min Chyuan Rd.
Shin Tien City, Taipei 231
Taiwan

Fertigungsstätte *Manufacturing Plant*

Zippy Technology Corp.
2F, No. 123, Lane 235
Pao-Chiao Rd.
Shin Tien City, Taipei Hsien 231
Taiwan

Prüfzeichen *Test Mark*

Geprüft nach *Tested acc. to*
EN 60950-1:2006+A11

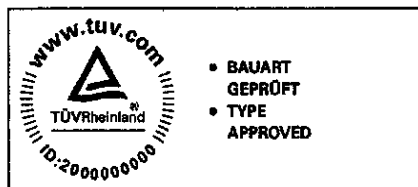

Zertifiziertes Produkt (Geräteidentifikation)
Certified Product (Product Identification)

Lizenzentgelte - Einheit
License Fee - Unit

Einbau-Schaltnetzteil (Redundant Power Supply and Power Module)

wie Blatt (as page) 01
Fortsetzung (Continuation)
Ausgangsspannung: +5V +12V +3.3V -12V +5VSB
(Output Voltage)
Ausgangsstrom : 0-32A 0-87A 0-32A 0-0.8A 0-3.5A
(Output Current)
max. Ausgangsleistung für +5V & +3.3V: 180W
(max. Output Power for +5V & +3.3V)
max. Ausgangsleistung : 1) 1010W
(max. Output Power) 2) 1050W



Vermerke: Primär- und Sekundärkreise sind gemäß Verfahren 1 nach Abschnitt 2.9.4 getrennt. Der Einbau muß gemäß der zugehörigen Einbauanweisung erfolgen. (Remarks: Primary and secondary circuits are separated according to method 1 of clause 2.9.4. The installation has to be carried out according to the attached installation instructions.)

ANLAGE (Appendix): 1

Dem Zertifikat liegt unsere Prüf- und Zertifizierungsordnung zugrunde und es bestätigt die Konformität des Produktes mit den oben genannten Standards und Prüfgrundlagen. Zusätzliche Anforderungen in Ländern, in denen das Produkt in Verkehr gebracht werden soll, müssen zusätzlich betrachtet werden. Die Herstellung des zertifizierten Produktes wird überwacht.
This certificate is based on our Testing and Certification Regulation and states the conformity of the product with the standards and testing requirements as indicated above. Any additional requirements in countries where the product is going to be marketed have to be considered additionally. The manufacturing of the certified product is subject to surveillance.

Zertifizierungsstelle

Dipl.-Ing. F. Stoelzel

TÜV Rheinland LGA Products GmbH - Tillystraße 2 - 90431 Nürnberg
Tel.: (+49/221)8 06 - 13 71 e-mail: cert-validity@de.tuv.com
Fax: (+49/221)8 06 - 39 35 http://www.tuv.com/safety

Zertifikat

Certificate



Zertifikat Nr. *Certificate No.*
R 50177272

Blatt *Page*
0003

Ihr Zeichen *Client Reference*
EH/SPC-1002041-spc

Unser Zeichen *Our Reference*
ZTW1-HCR- 10028417 001

Ausstellungsdatum
18.03.2010

Date of Issue
(day/month/year)

Genehmigungsinhaber *License Holder*
Zippy Technology Corp.
10F., No. 50, Min Chyuan Rd.
Shin Tien City, Taipei 231
Taiwan

Fertigungsstätte *Manufacturing Plant*
Zippy Technology Corp.
2F, No. 123, Lane 235
Pao-Chiao Rd.
Shin Tien City, Taipei Hsien 231
Taiwan

Prüfzeichen *Test Mark*

Geprüft nach *Tested acc. to*
EN 60950-1:2006+A11

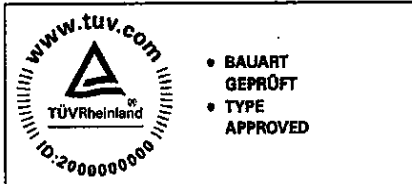

Zertifiziertes Produkt (Geräteidentifikation)
Certified Product (Product Identification)

Lizenzentgelte - Einheit
License Fee - Unit

Einbau-Schaltnetzteil (Redundant Power Supply and Power Module)

wie Blatt (as page) 01

Ergänzung
(Addition)

Bezeichnung (Type Designation) : 1) C2W-5bV (EMACS)
C2W-3bV-R (EMACS)
2) C2W-3A50V-R (EMACS)

b steht für (stands for): 620 oder (or) 820

Nennspannung (Rated Voltage) : 1) AC 100-240V, 47-63Hz
2a) AC 100-240V, 47-63Hz
2b) AC 200-240V, 47-63Hz

Nennstrom (Rated Current) : 1) 10-5A (b=620); 13-6.5A (b=820)
2a) 15-7A
2b) 7.5A

Ausgang (Output) : siehe Aufbau-Übersicht
(see constructional dataform)



1
1
1
1

4

ANLAGE (Appendix): 1

Dem Zertifikat liegt unsere Prüf- und Zertifizierungsordnung zugrunde und es bestätigt die Konformität des Produktes mit den oben genannten Standards und Prüfgrundlagen. Zusätzliche Anforderungen in Ländern, in denen das Produkt in Verkehr gebracht werden soll, müssen zusätzlich betrachtet werden. Die Herstellung des zertifizierten Produktes wird überwacht.
This certificate is based on our Testing and Certification Regulation and states the conformity of the product with the standards and testing requirements as indicated above. Any additional requirements in countries where the product is going to be marketed have to be considered additionally. The manufacturing of the certified product is subject to surveillance.

Zertifizierungsstelle

Dipl.-Ing. F. Stöckel

TÜV Rheinland LGA Products GmbH - Tillystraße 2 - 90431 Nürnberg
Tel.: (+49/221)8 06 - 13 71 e-mail: cert-validity@de.tuv.com
Fax: (+49/221)8 06 - 39 35 http://www.tuv.com/safety

Declaration of Conformity

We, Manufacturer

ZIPPY TECHNOLOGY CORP.
10F,No.50,MIN CHYUAN RD.
SHIN-TIEN, TAIPEI HSIEN
TAIWAN, R.O.C.

declare that the product
(description of the apparatus, system, installation to which it refers)

SWITCHING POWER SUPPLY C2W-5620V

is in conformity with
(reference to the specification under which conformity is declared)
i in accordance with 2004/108/EC-EMC Directive

- | | |
|---|---|
| ■ EN 55022 : 2006+A1/2007
Information technology equipment
-Radio disturbance characteristics
-Limits and methods of measurement | ■ EN 61000-4-5: 2006 Criteria B
Surge Immunity requirements |
| ■ EN 55024 : 1998+A1/2001+A2/2003
Information technology equipment
-Immunity characteristics
-Limits and methods of measurement | ■ EN 61000-4-6: 2007 Criteria A
Conducted Immunity |
| ■ EN 61000-4-2 :1995+A2/2001 Criteria B
Electrostatic discharge requirements "ESD" | ■ EN 61000-4-8: 1993+A1/2001 Criteria A
Power Frequency Magnetic Field Immunity |
| ■ EN 61000-4-3 :2006 Criteria A
Radiated, radio frequency electromagnetic field | ■ EN 61000-4-11:2004
Dip Criteria B
Interruptions Criteria C
Voltage Dip,interruptions Immunity requirements |
| ■ EN 61000-4-4 : 2004 Criteria B
Electrical fast transient requirements "EFT" | ■ EN 61000-3-2 :2006
Harmonic current requirements |
| | ■ EN 61000-3-3 :1995+A1/2001+A2/2005
Voltage fluctuations and flicker requirements |

Manufacturer	
Date :	MAR,25,2010
Signature:	<u>Jeff Huang</u>
Name:	<u>ZIPPY</u>

Test-Lab	
Date :	MAR,25,2010
Signature:	<u>Karen</u>
Name:	<u>ZIPPY</u>

conduction test

EUT: C2W-5620V SPS
 Manuf: ZIPPY TECH CO..LTD
 Op Cond: FULL LOAD
 Operator:
 Test Spec: EN 55022-- Class B
 Comment: Load Condition (36 20 0.8 18 3.5)
 L110V

Scan Settings (3 Ranges)

Frequencies			Receiver Settings					
Start	Stop	Step	IF BW	Detector	M-Time	Atten	Preamp	OpRge
150kHz	500kHz	2kHz	10kHz	QP+AV	1msec	Auto	OFF	60dB
500kHz	5MHz	20kHz	10kHz	QP+AV	1msec	Auto	OFF	60dB
5MHz	30MHz	50kHz	10kHz	QP+AV	1msec	Auto	OFF	60dB

Transducer	No.	Start	Stop	Name
	1	9kHz	30MHz	CEB

Prescan Measurement: Detectors: X QP / + AV
 Meas Time: see scan settings
 Peaks: 8
 Acc Margin: 25 dB

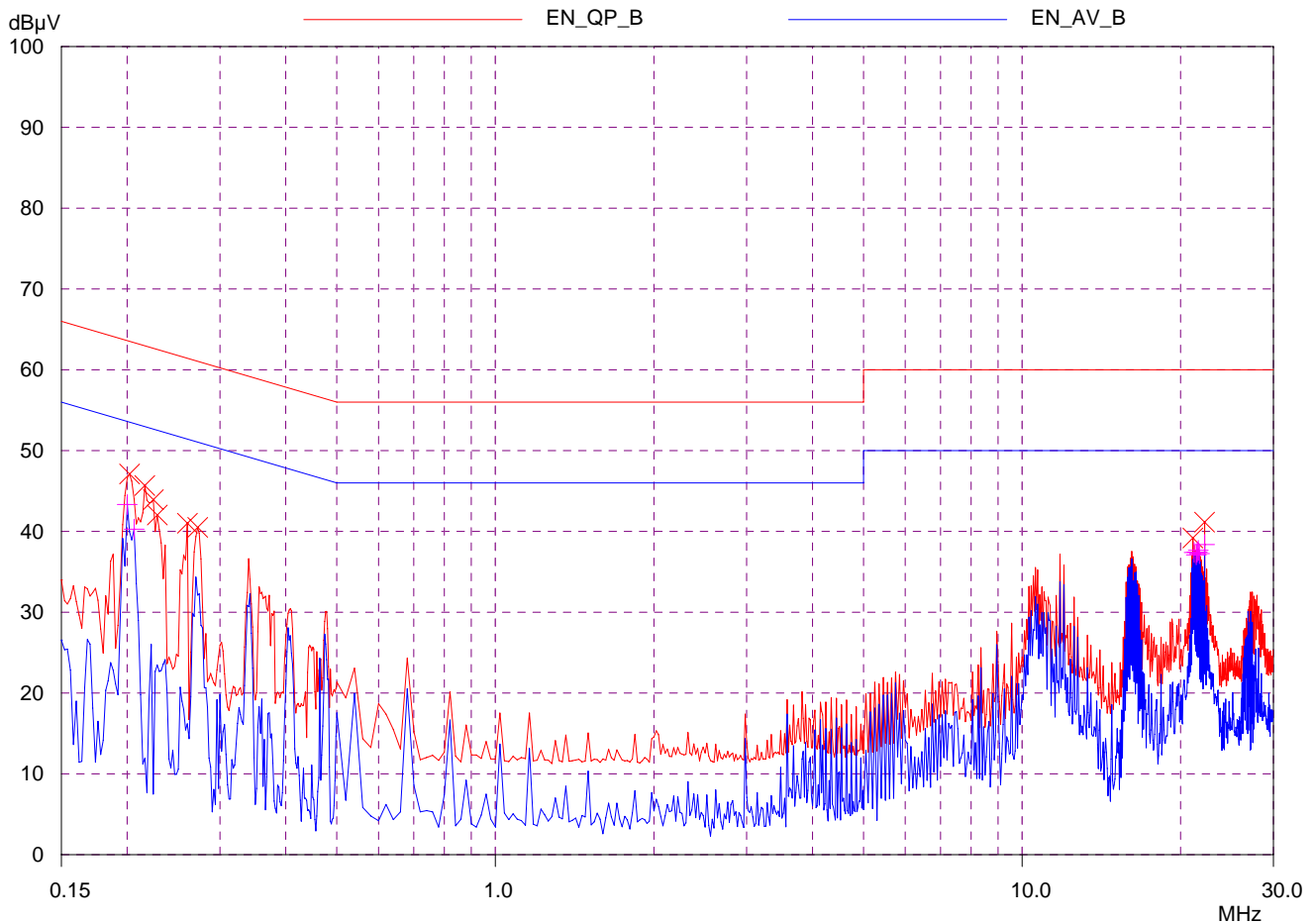

conduction test

EUT: C2W-5620V SPS
 Manuf: ZIPPY TECH CO..LTD
 Op Cond: FULL LOAD
 Operator:
 Test Spec: EN 55022-- Class B
 Comment: Load Condition (36 20 0.8 18 3.5)
 L110V

Scan Settings (3 Ranges)

Frequencies				Receiver Settings				
Start	Stop	Step	IF BW	Detector	M-Time	Atten	Preamp	OpRge
150kHz	500kHz	2kHz	10kHz	QP+AV	1msec	Auto	OFF	60dB
500kHz	5MHz	20kHz	10kHz	QP+AV	1msec	Auto	OFF	60dB
5MHz	30MHz	50kHz	10kHz	QP+AV	1msec	Auto	OFF	60dB

Transducer	No.	Start	Stop	Name
	1	9kHz	30MHz	CEB

Prescan Measurement: Detectors: X QP / + AV
 Meas Time: see scan settings
 Peaks: 8
 Acc Margin: 25 dB

Peak Search Results

Frequency MHz	QP Level dBµV	QP Limit dBµV	QP Delta dB	Phase	PE
0.202	47.11	63.53	16.42	N	gnd
0.216	45.69	62.97	17.28	N	gnd
0.224	43.94	62.67	18.73	N	gnd
0.228	42.03	62.52	20.49	N	gnd
0.26	41.02	61.43	20.41	N	gnd
0.272	40.51	61.06	20.55	N	gnd
21.1	39.18	60.00	20.82	N	gnd
22.2	41.15	60.00	18.85	N	gnd

Frequency MHz	AV Level dBµV	AV Limit dBµV	AV Delta dB	Phase	PE
0.2	43.34	53.61	10.27	N	gnd
0.206	40.27	53.37	13.10	N	gnd
21.2	37.41	50.00	12.59	N	gnd
21.4	37.11	50.00	12.89	N	gnd
21.5	37.44	50.00	12.56	N	gnd
21.6	37.67	50.00	12.33	N	gnd
21.7	37.25	50.00	12.75	N	gnd
22.2	38.38	50.00	11.62	N	gnd

* limit exceeded

Indicated Phase/PE shows Configuration of max. Emission

conduction test

EUT: C2W-5620V SPS
 Manuf: ZIPPY TECH CO..LTD
 Op Cond: FULL LOAD
 Operator:
 Test Spec: EN 55022-- Class B
 Comment: Load Condition (36 20 0.8 18 3.5)
 N110V

Scan Settings (3 Ranges)

Frequencies			Receiver Settings					
Start	Stop	Step	IF BW	Detector	M-Time	Atten	Preamp	OpRge
150kHz	500kHz	2kHz	10kHz	QP+AV	1msec	Auto	OFF	60dB
500kHz	5MHz	20kHz	10kHz	QP+AV	1msec	Auto	OFF	60dB
5MHz	30MHz	50kHz	10kHz	QP+AV	1msec	Auto	OFF	60dB

Transducer	No.	Start	Stop	Name
	1	9kHz	30MHz	CEB

Prescan Measurement: Detectors: X QP / + AV
 Meas Time: see scan settings
 Peaks: 8
 Acc Margin: 25 dB

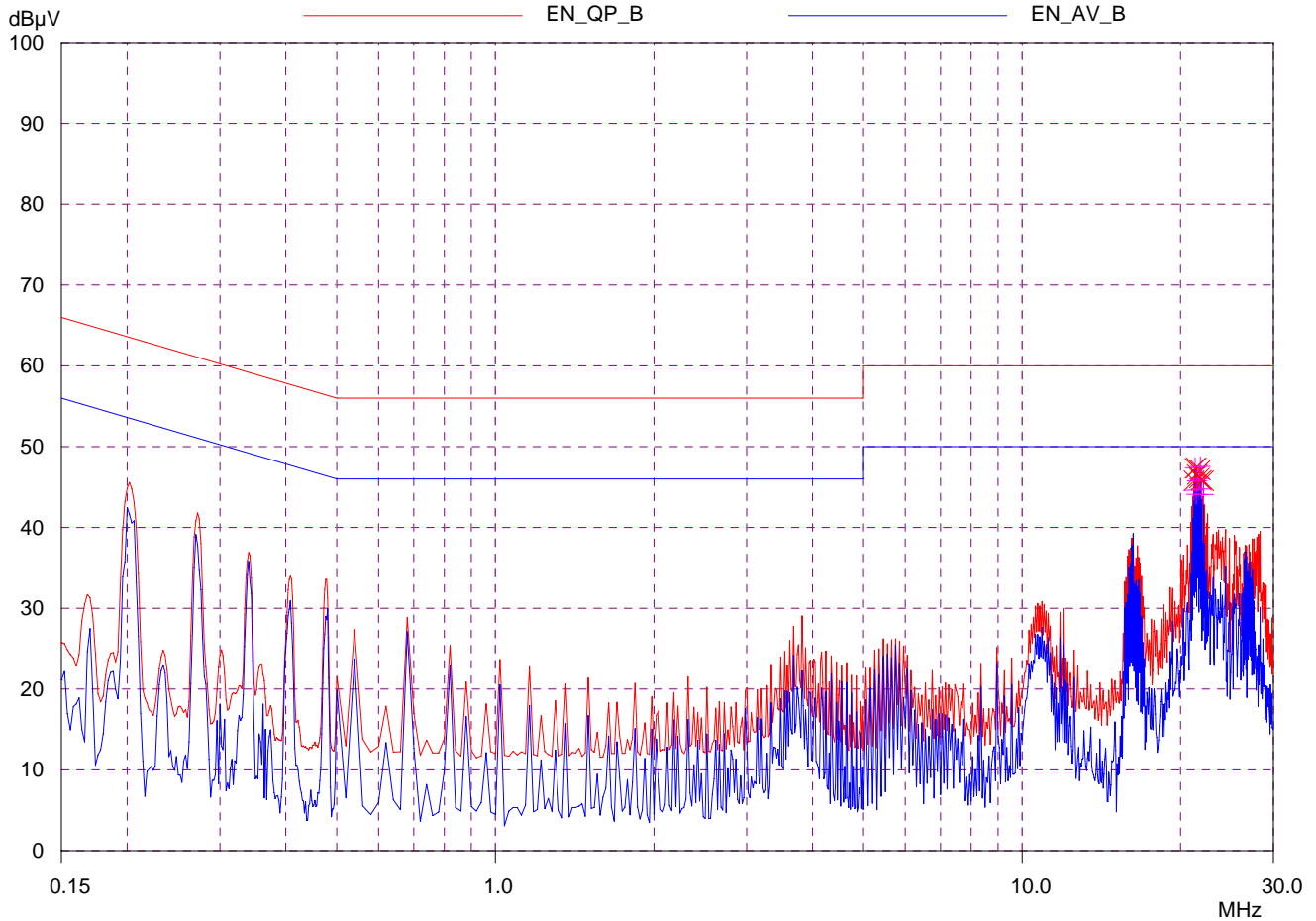

ZIPPY EMC LAB

25 Mar 2010 15:13

conduction test

EUT: C2W-5620V SPS
 Manuf: ZIPPY TECH CO..LTD
 Op Cond: FULL LOAD
 Operator:
 Test Spec: EN 55022-- Class B
 Comment: Load Condition (36 20 0.8 18 3.5)
 N110V

Scan Settings (3 Ranges)

Frequencies				Receiver Settings				
Start	Stop	Step	IF BW	Detector	M-Time	Atten	Preamp	OpRge
150kHz	500kHz	2kHz	10kHz	QP+AV	1msec	Auto	OFF	60dB
500kHz	5MHz	20kHz	10kHz	QP+AV	1msec	Auto	OFF	60dB
5MHz	30MHz	50kHz	10kHz	QP+AV	1msec	Auto	OFF	60dB

Transducer	No.	Start	Stop	Name
	1	9kHz	30MHz	CEB

Prescan Measurement: Detectors: X QP / + AV
 Meas Time: see scan settings
 Peaks: 8
 Acc Margin: 25 dB

Peak Search Results

Frequency MHz	QP Level dBμV	QP Limit dBμV	QP Delta dB	Phase	PE
21.2	45.76	60.00	14.24	N	gnd
21.3	47.31	60.00	12.69	N	gnd
21.4	47.39	60.00	12.61	N	gnd
21.5	46.53	60.00	13.47	N	gnd
21.7	46.11	60.00	13.89	N	gnd
21.8	47.09	60.00	12.91	N	gnd
21.9	45.84	60.00	14.16	N	gnd
22.1	45.78	60.00	14.22	N	gnd

Frequency MHz	AV Level dBμV	AV Limit dBμV	AV Delta dB	Phase	PE
21.2	44.60	50.00	5.40	N	gnd
21.3	47.41	50.00	2.59	N	gnd
21.4	44.10	50.00	5.90	N	gnd
21.5	45.79	50.00	4.21	N	gnd
21.7	46.06	50.00	3.94	N	gnd
21.8	47.55	50.00	2.45	N	gnd
21.9	44.77	50.00	5.23	N	gnd
22.1	44.09	50.00	5.91	N	gnd

* limit exceeded

Indicated Phase/PE shows Configuration of max. Emission



ZIPPY TECHNOLOGY CORP.

10F, No. 50, MIN CHYUAN RD

SHIN-TIEN, TAIPEI HSIEN, TAIWAN

RoHS REPORT

Issue Date : 2010/03/22
Model Name : C2W-5620V
Part Number : B00C2W062Vxxx
Approved by : Meloan Lin
Review by : Edment Lin
Form maker : Mavis Chen



Power Division

MODEL : C2W-5620V

Description	Supplier	Cd (ppm)	Pb (ppm)	Hg(ppm)	Cr VI(ppm)	PBB(ppm)	PBDE(ppm)	Test report No.	Exemption
IC LTV817X-B	LITEON	N.D.	14	N.D.	N.D.	*	*	CE_2007_45770	
IC AP432SRG-7 SOT23R SMD	DIODES	N.D.	6.8	N.D.	N.D.	N.D.	N.D.	CE_2006_82833	
IC LM324DT SO14 SMD	ST	N.D.	7	N.D.	N.D.	N.D.	N.D.	CE_2007_80659	
IC LM393DT SO8 SMD	ST	N.D.	7	N.D.	N.D.	N.D.	N.D.	CE_2007_80659	
IC HA17431VP	RENESAS	N.D.	N.D.	N.D.	N.D.	N.D.	N.D.	data_HA17431	
IC WT7510-SN080WT (SMD)	WELTREND	N.D.	8.44	N.D.	N.D.	N.D.	N.D.	KA_2008_C1794A-02	
IC NJM431U SOT-89 SMD (JRC)	New Japan Radio	N.D.	9.2	N.D.	N.D.	N.D.	N.D.	10130370_08(2)	
IC NCP1280DR2G SO-16 SMD	ON	N.D.	20	N.D.	N.D.	N.D.	N.D.	KA_2008_C1794A~14252-08	
IC MC34152DR2G SOIC-8 SMD	ON	N.D.	20	N.D.	N.D.	N.D.	N.D.	KA_2008_C1794A~14252-08	
IC NCP1653ADR2G SO-8 SMD	ON	N.D.	20	N.D.	N.D.	N.D.	N.D.	KA_2008_C1794A~14252-08	
IC NCP5006 TSOP-5 SMD	ON	N.D.	20	N.D.	N.D.	N.D.	N.D.	KA_2008_C1794A~14252-08	
IC NJM78L05UA SOT-89 SMD	JRC	N.D.	9.2	N.D.	N.D.	N.D.	N.D.	10130370_08(2)	
IC ISL6545CBZ-T SO-8 SMD	AMS	N.D.	N.D.	N.D.	N.D.	N.D.	N.D.	CE_2008_B6968B	
IC IR5001STRPBF SO-8 SMD	IR	N.D.	20.1	N.D.	N.D.	N.D.	N.D.	CE_2006_C1959	
IC P89LPC915 SMD TSSOP14(空白)	NXP	N.D.	23	N.D.	N.D.	N.D.	N.D.	CE_2008_47293	
IC SG6858 SOT-26 SMD	FAIRCHILD	N.D.	N.D.	N.D.	N.D.	N.D.	N.D.	CE_2008_C3582	
IC WT7507-SN164 SMD SOP-16	WELTREND	N.D.	36	N.D.	N.D.	N.D.	N.D.	CE_2008_A2656	
IC FP702KR-LF SOT-25 SMD	FEELING	N.D.	16	N.D.	N.D.	N.D.	N.D.	CE_2007_B5295	
IC F75387SG 16SOP SMD FINTEK	FINTEK	N.D.	N.D.	N.D.	N.D.	N.D.	N.D.	CE_2007_756546	
TR 2SB1260T100Q PNP SMD SC-62	ROHM	N.D.	N.D.	N.D.	N.D.	N.D.	N.D.	CE_2007_45392	
TR 2SC5053 NPN TAPPING SMD	SILICON	N.D.	N.D.	N.D.	N.D.	N.D.	N.D.	CE_2008_47204	
TR MMBT2222ALT1 (600mA/40V)SMD	SILICON	N.D.	N.D.	N.D.	N.D.	N.D.	N.D.	CE_2008_47204	
TR SST2907A TAPPING SMD SST3	SILICON	N.D.	N.D.	N.D.	N.D.	N.D.	N.D.	CE_2008_47204	
MOSFET 2N7002 (300mA/60V) SMD	SILICON	N.D.	N.D.	N.D.	N.D.	N.D.	N.D.	CE_2008_47204	
TR 2SB772PA (非絶縁型) (NEC)	SILICON	N.D.	N.D.	N.D.	N.D.	N.D.	N.D.	CE_2008_47204	
MOSFET IRFB3307PbF (120A/75V)	ZENITRON	N.D.	N.D.	N.D.	N.D.	N.D.	N.D.	CE_2008_33990	
MOSFET IRF1404PbF (202A/40V)	ZENITRON	N.D.	N.D.	N.D.	N.D.	N.D.	N.D.	CE_2008_33990	
TR MMBT2907ALT1G (600mA/60V)	SILICON	N.D.	N.D.	N.D.	N.D.	N.D.	N.D.	CE_2008_47204	
MOSFET BSC030N03LSG(100A/30V)	INFINEON	N.D.	N.D.	N.D.	N.D.	N.D.	N.D.	CE_2007_61789	
TR 2N3906G (200mA/40V) TO-92	ON	N.D.	N.D.	N.D.	N.D.	N.D.	N.D.	LPCI_13842_08	
MOSFET SIHP22N60S-E3(22A/600V)	VISHAY	N.D.	53	N.D.	N.D.	N.D.	N.D.	SIHP22N60S-E3	
MOSFET SPA11N80C3 (11A/800V)	INFINEON	N.D.	35	N.D.	N.D.	N.D.	N.D.	CE_2009_50882	
DIODE RLS4148N SMD LL-34	ROHM	N.D.	N.D.	N.D.	N.D.	N.D.	N.D.	CE_2007_45392	
DIODE 1N5408 DO-201AD	PANJIT	N.D.	43.5	N.D.	N.D.	N.D.	N.D.	KA_2009_10683A-01	
DIODE-ZENER TZMC16-GS08 16V	VISHAY							Supplier self declartion	
DIODE-ZENER ZMM55-C13 13V SMD	PANJIT	N.D.	N.D.	N.D.	N.D.	N.D.	N.D.	KA_2006_32822	
DIODE-ZENER ZMM55-C3V6 3.6V	PANJIT	N.D.	N.D.	N.D.	N.D.	N.D.	N.D.	KA_2006_32822	
SCHOTTKY SS14(1A/40V) SMD	PAJ JIT	N.D.	43.5	N.D.	N.D.	N.D.	N.D.	KA_2009_10683A-01	
FAST ER204 (2A/400V) TAPPING	PANJIT	N.D.	43.5	N.D.	N.D.	N.D.	N.D.	KA_2009_10683A-01	
FAST UF208G (2A/800V) DO-15	PANJIT	N.D.	43.5	N.D.	N.D.	N.D.	N.D.	KA_2009_10683A-01	
BRIDGE D25XB60-7000 (25A/600V)	SHINDENGEN	N.D.	N.D.	N.D.	N.D.	N.D.	N.D.	CE_2006_85040	
LED 一般亮 緑色 3mm(圓型)	早安(YSTONE)	N.D.	7	N.D.	N.D.	N.D.	N.D.	TWNC00078201	
LED BL-HG033-TR 黄緑 1206 SMD	早安(YSTONE)	N.D.	6.7	N.D.	N.D.	N.D.	N.D.	CE_2006_54355	

MODEL : C2W-5620V

Description	Supplier	Cd (ppm)	Pb (ppm)	Hg(ppm)	Cr VI(ppm)	PBB(ppm)	PBDE(ppm)	Test report No.	Exemption
C/R 0Ω 1/4W 5% SMD 1206	泰銘(TMTEC)	N.D.	632	N.D.	N.D.	N.D.	N.D.	KA_2007_51789	
C/R 1.5K 1/4W 1% SMD 1206	泰銘(TMTEC)	N.D.	632	N.D.	N.D.	N.D.	N.D.	KA_2007_51789	
C/R 100Ω 1/4W 1% SMD 1206	泰銘(TMTEC)	N.D.	632	N.D.	N.D.	N.D.	N.D.	KA_2007_51789	
C/R 10K 1/4W 1% SMD 1206	泰銘(TMTEC)	N.D.	632	N.D.	N.D.	N.D.	N.D.	KA_2007_51789	
C/R 10K 1/8W 1% SMD 0805	TA-I	N.D.	6	N.D.	N.D.	N.D.	N.D.	CE_2009_11821A~	
C/R 10Ω 1/4W 1% SMD 1206	泰銘(TMTEC)	N.D.	632	N.D.	N.D.	N.D.	N.D.	KA_2007_51789	
C/R 15Ω 1/4W 1% SMD 1206	泰銘(TMTEC)	N.D.	632	N.D.	N.D.	N.D.	N.D.	KA_2007_51789	
C/R 1K 1/4W 1% SMD 1206	泰銘(TMTEC)	N.D.	632	N.D.	N.D.	N.D.	N.D.	KA_2007_51789	
C/R 1K 1/8W 1% SMD 0805	TA-I	N.D.	6	N.D.	N.D.	N.D.	N.D.	CE_2009_11821A~	
C/R 1M 1/4W 1% SMD 1206	泰銘(TMTEC)	N.D.	632	N.D.	N.D.	N.D.	N.D.	KA_2007_51789	
C/R 1M 1/4W 帶狀	彩源(TZAI YUAN)	N.D.	N.D.	N.D.	N.D.	N.D.	N.D.	SH6147834-1_CHEM	
C/R 22Ω 1/4W 1% SMD 1206	泰銘(TMTEC)	N.D.	632	N.D.	N.D.	N.D.	N.D.	KA_2007_51789	
C/R 2K 1/4W 1% SMD 1206	泰銘(TMTEC)	N.D.	632	N.D.	N.D.	N.D.	N.D.	KA_2007_51789	
C/R 2K 1/8W 1% SMD 0805	TA-I	N.D.	6	N.D.	N.D.	N.D.	N.D.	CE_2009_11821A~	
C/R 30K 1/4W 1% SMD 1206	泰銘(TMTEC)	N.D.	632	N.D.	N.D.	N.D.	N.D.	KA_2007_51789	
C/R 330Ω 1/4W 1% SMD 1206	泰銘(TMTEC)	N.D.	632	N.D.	N.D.	N.D.	N.D.	KA_2007_51789	
C/R 33Ω 1/4W 1% SMD 1206	泰銘(TMTEC)	N.D.	632	N.D.	N.D.	N.D.	N.D.	KA_2007_51789	
C/R 390K 1/4W 1% SMD 1206	泰銘(TMTEC)	N.D.	632	N.D.	N.D.	N.D.	N.D.	KA_2007_51789	
C/R 3K 1/8W 1% SMD 0805	TA-I	N.D.	6	N.D.	N.D.	N.D.	N.D.	CE_2009_11821A~	
C/R 4.3K 1/4W 1% SMD 1206	泰銘(TMTEC)	N.D.	632	N.D.	N.D.	N.D.	N.D.	KA_2007_51789	
C/R 4.3K 1/8W 1% SMD 0805	TA-I	N.D.	6	N.D.	N.D.	N.D.	N.D.	CE_2009_11821A~	
C/R 4.7K 1/4W 1% SMD 1206	泰銘(TMTEC)	N.D.	632	N.D.	N.D.	N.D.	N.D.	KA_2007_51789	
C/R 4.7K 1/8W 1% SMD 0805	TA-I	N.D.	6	N.D.	N.D.	N.D.	N.D.	CE_2009_11821A~	
C/R 4.7Ω 1/4W 1% SMD 1206	泰銘(TMTEC)	N.D.	632	N.D.	N.D.	N.D.	N.D.	KA_2007_51789	
C/R 470K 1/4W 1% SMD 1206	泰銘(TMTEC)	N.D.	632	N.D.	N.D.	N.D.	N.D.	KA_2007_51789	
C/R 470Ω 1/8W 1% SMD 0805	TA-I	N.D.	6	N.D.	N.D.	N.D.	N.D.	CE_2009_11821A~	
C/R 510K 1/4W 1% SMD 1206	泰銘(TMTEC)	N.D.	632	N.D.	N.D.	N.D.	N.D.	KA_2007_51789	
C/R 510Ω 1/8W 1% SMD 0805	TA-I	N.D.	6	N.D.	N.D.	N.D.	N.D.	CE_2009_11821A~	
C/R 51Ω 1/4W 1% SMD 1206	泰銘(TMTEC)	N.D.	632	N.D.	N.D.	N.D.	N.D.	KA_2007_51789	
C/R 56K 1/4W 1% SMD 1206	泰銘(TMTEC)	N.D.	632	N.D.	N.D.	N.D.	N.D.	KA_2007_51789	
C/R 7.5K 1/4W 1% SMD 1206	泰銘(TMTEC)	N.D.	632	N.D.	N.D.	N.D.	N.D.	KA_2007_51789	
C/R 750K 1/4W 1% SMD 1206	泰銘(TMTEC)	N.D.	632	N.D.	N.D.	N.D.	N.D.	KA_2007_51789	
C/R 3.6M 1/4W 1% SMD 1206	泰銘(TMTEC)	N.D.	632	N.D.	N.D.	N.D.	N.D.	KA_2007_51789	
C/R 2.2M 1/4W 1% SMD 1206	泰銘(TMTEC)	N.D.	632	N.D.	N.D.	N.D.	N.D.	KA_2007_51789	
C/R 20K 1/8W 1% SMD 0805	TA-I	N.D.	6	N.D.	N.D.	N.D.	N.D.	CE_2009_11821A~	
C/R 30K 1/8W 1% SMD 0805	TA-I	N.D.	6	N.D.	N.D.	N.D.	N.D.	CE_2009_11821A~	
C/R 22K 1/8W 1% SMD 0805	TA-I	N.D.	6	N.D.	N.D.	N.D.	N.D.	CE_2009_11821A~	
C/R 2.7K 1/8W 1% SMD 0805	TA-I	N.D.	6	N.D.	N.D.	N.D.	N.D.	CE_2009_11821A~	
C/R 330K 1/8W 1% SMD 0805	TA-I	N.D.	6	N.D.	N.D.	N.D.	N.D.	CE_2009_11821A~	
C/R 33Ω 1/8W 1% SMD 0805	TA-I	N.D.	6	N.D.	N.D.	N.D.	N.D.	CE_2009_11821A~	
C/R 47Ω 1/8W 1% SMD 0805	TA-I	N.D.	6	N.D.	N.D.	N.D.	N.D.	CE_2009_11821A~	
C/R 100K 1/8W 1% SMD 0805	TA-I	N.D.	6	N.D.	N.D.	N.D.	N.D.	CE_2009_11821A~	

MODEL : C2W-5620V

Description	Supplier	Cd (ppm)	Pb (ppm)	Hg(ppm)	Cr VI(ppm)	PBB(ppm)	PBDE(ppm)	Test report No.	Exemption
C/R 24K 1/8W 1% SMD 0805	TA-I	N.D.	6	N.D.	N.D.	N.D.	N.D.	CE_2009_11821A~	
C/R 3.3K 1/8W 1% SMD 0805	TA-I	N.D.	6	N.D.	N.D.	N.D.	N.D.	CE_2009_11821A~	
C/R 0Ω 1/8W 5% SMD 0805	TA-I	N.D.	6	N.D.	N.D.	N.D.	N.D.	CE_2009_11821A~	
C/R 1.1K 1/8W 1% SMD 0805	TA-I	N.D.	6	N.D.	N.D.	N.D.	N.D.	CE_2009_11821A~	
C/R 1.8K 1/8W 1% SMD 0805	TA-I	N.D.	6	N.D.	N.D.	N.D.	N.D.	CE_2009_11821A~	
C/R 470K 1/8W 1% SMD 0805	TA-I	N.D.	6	N.D.	N.D.	N.D.	N.D.	CE_2009_11821A~	
C/R 10Ω 1/8W 1% SMD 0805	TA-I	N.D.	6	N.D.	N.D.	N.D.	N.D.	CE_2009_11821A~	
C/R 1.2K 1/8W 1% SMD 0805	TA-I	N.D.	6	N.D.	N.D.	N.D.	N.D.	CE_2009_11821A~	
C/R 100Ω 1/8W 1% SMD 0805	TA-I	N.D.	6	N.D.	N.D.	N.D.	N.D.	CE_2009_11821A~	
C/R 22Ω 1/8W 1% SMD 0805	TA-I	N.D.	6	N.D.	N.D.	N.D.	N.D.	CE_2009_11821A~	
C/R 2.2K 1/8W 1% SMD 0805	TA-I	N.D.	6	N.D.	N.D.	N.D.	N.D.	CE_2009_11821A~	
C/R 47K 1/8W 1% SMD 0805	TA-I	N.D.	6	N.D.	N.D.	N.D.	N.D.	CE_2009_11821A~	
C/R 4.7Ω 1/8W 1% SMD 0805	TA-I	N.D.	6	N.D.	N.D.	N.D.	N.D.	CE_2009_11821A~	
C/R 2.4K 1/8W 1% SMD 0805	TA-I	N.D.	6	N.D.	N.D.	N.D.	N.D.	CE_2009_11821A~	
C/R 560Ω 1/8W 1% SMD 0805	TA-I	N.D.	6	N.D.	N.D.	N.D.	N.D.	CE_2009_11821A~	
C/R 1.5K 1/8W 1% SMD 0805	TA-I	N.D.	6	N.D.	N.D.	N.D.	N.D.	CE_2009_11821A~	
C/R 300Ω 1/8W 1% SMD 0805	TA-I	N.D.	6	N.D.	N.D.	N.D.	N.D.	CE_2009_11821A~	
C/R 220Ω 1/8W 1% SMD 0805	TA-I	N.D.	6	N.D.	N.D.	N.D.	N.D.	CE_2009_11821A~	
C/R 5.6K 1/8W 1% SMD 0805	TA-I	N.D.	6	N.D.	N.D.	N.D.	N.D.	CE_2009_11821A~	
C/R 1.5Ω 1/8W 1% SMD 0805	TA-I	N.D.	6	N.D.	N.D.	N.D.	N.D.	CE_2009_11821A~	
C/R 8.2K 1/8W 1% SMD 0805	TA-I	N.D.	6	N.D.	N.D.	N.D.	N.D.	CE_2009_11821A~	
C/R 15K 1/8W 1% SMD 0805	TA-I	N.D.	6	N.D.	N.D.	N.D.	N.D.	CE_2009_11821A~	
C/R 12Ω 1/4W 1% SMD 1206	泰銘(TMTEC)	N.D.	632	N.D.	N.D.	N.D.	N.D.	KA_2007_51789	
C/R 3.09K 1/8W 1% SMD 0805	TA-I	N.D.	6	N.D.	N.D.	N.D.	N.D.	CE_2009_11821A~	
C/R 150Ω 1/8W 1% SMD 0805	TA-I	N.D.	6	N.D.	N.D.	N.D.	N.D.	CE_2009_11821A~	
C/R 240K 1/8W 1% SMD 0805	TA-I	N.D.	6	N.D.	N.D.	N.D.	N.D.	CE_2009_11821A~	
C/R 430K 1/8W 1% SMD 0805	TA-I	N.D.	6	N.D.	N.D.	N.D.	N.D.	CE_2009_11821A~	
C/R 180Ω 1/8W 1% SMD 0805	TA-I	N.D.	6	N.D.	N.D.	N.D.	N.D.	CE_2009_11821A~	
C/R 2.49K 1/8W 1% SMD 0805	TA-I	N.D.	6	N.D.	N.D.	N.D.	N.D.	CE_2009_11821A~	
C/R 240Ω 1/8W 1% SMD 0805	TA-I	N.D.	6	N.D.	N.D.	N.D.	N.D.	CE_2009_11821A~	
C/R 1.6K 1/8W 1% SMD 0805	TA-I	N.D.	6	N.D.	N.D.	N.D.	N.D.	CE_2009_11821A~	
C/R 300K 1/8W 1% SMD 0805	TA-I	N.D.	6	N.D.	N.D.	N.D.	N.D.	CE_2009_11821A~	
C/R 12.1K 1/8W 1% SMD 0805	TA-I	N.D.	6	N.D.	N.D.	N.D.	N.D.	CE_2009_11821A~	
C/R 2.4M 1/4W 1% SMD 1206	泰銘(TMTEC)	N.D.	632	N.D.	N.D.	N.D.	N.D.	KA_2007_51789	
C/R 3.6K 1/8W 1% SMD 0805	TA-I	N.D.	6	N.D.	N.D.	N.D.	N.D.	CE_2009_11821A~	
C/R 270K 1/8W 1% SMD 0805	TA-I	N.D.	6	N.D.	N.D.	N.D.	N.D.	CE_2009_11821A~	
C/R 100Ω 1/10W 0.1% SMD 0805	TA-I	N.D.	6	N.D.	N.D.	N.D.	N.D.	CE_2009_11821A~	
M/R 100K 1W 散狀	彩源(TZAI YUAN)	N.D.	N.D.	N.D.	N.D.	N.D.	N.D.	SH1478374-1_CHEM	
M/R 220K 小3W 散狀	彩源(TZAI YUAN)	N.D.	N.D.	N.D.	N.D.	N.D.	N.D.	SH1478374-1_CHEM	
M/R 0.75Ω 小3W 散狀 (無感)	彩源(TZAI YUAN)	N.D.	N.D.	N.D.	N.D.	N.D.	N.D.	SH1478374-1_CHEM	
VR G43AT102M-1K 臥式 SMD	BOURNS	N.D.	64	N.D.	N.D.	N.D.	N.D.	2007_g43_series	
VR G43ATB201M-200 臥式 SMD	TOKYO	N.D.	64	N.D.	N.D.	N.D.	N.D.	2007_g43_series	
T/R SCK-164 (16Ω/4A)	TKS	N.D.	N.D.	N.D.	N.D.	N.D.	N.D.	KA_2009_21960	

MODEL : C2W-5620V

Description	Supplier	Cd (ppm)	Pb (ppm)	Hg(ppm)	Cr VI(ppm)	PBB(ppm)	PBDE(ppm)	Test report No.	Exemption
T/R TTC-103(K) (10K)	TKS	N.D.	N.D.	N.D.	N.D.	N.D.	N.D.	KA_2009_21960	
RESISTOR 2mΩ 2W 1% SMD 2512	TT	N.D.	19	N.D.	N.D.	N.D.	N.D.	CE_2008_91254	
RESISTOR 1mΩ 2W 1% SMD 2512	TT	N.D.	19	N.D.	N.D.	N.D.	N.D.	CE_2008_91254	
RESISTOR 68mΩ 2W 1% SMD 2512	TT	N.D.	19	N.D.	N.D.	N.D.	N.D.	CE_2008_91254	
RESISTOR 50mΩ 2W 1% SMD 2512	TT	N.D.	19	N.D.	N.D.	N.D.	N.D.	CE_2008_91254	
I-S/C 0.68uf/275V 17.5x10x16	ULTRA	N.D.	250	N.D.	N.D.	N.D.	N.D.	CE_2007_42285.6.7.91.98-60620	
M/C 474/450V (NITSUKO)	NISSEI	3	315	N.D.	N.D.	N.D.	N.D.	MMX-series-combine	
M/C 473J/630V (0.047UF) NISSEI	NISSEI	3	315	N.D.	N.D.	N.D.	N.D.	MMX-series-combine	
S/C 102/50V(X7R) 10% SMD 0805	YAGEO	N.D.	N.D.	N.D.	N.D.	N.D.	N.D.	KA_2009_11324	
S/C 103/50V(X7R) 10% SMD 0805	YAGEO	N.D.	N.D.	N.D.	N.D.	N.D.	N.D.	KA_2009_11324	
S/C 103/50V(X7R) 10% SMD 1206	YAGEO	N.D.	N.D.	N.D.	N.D.	N.D.	N.D.	KA_2009_11324	
S/C 104/50V(X7R) 10% SMD 0805	YAGEO	N.D.	N.D.	N.D.	N.D.	N.D.	N.D.	KA_2009_11324	
S/C 105/16V(X7R) 10% 0805 SMD	YAGEO	N.D.	N.D.	N.D.	N.D.	N.D.	N.D.	KA_2009_11324	
S/C 105/16V(X7R) 10% SMD 1206	YAGEO	N.D.	N.D.	N.D.	N.D.	N.D.	N.D.	KA_2009_11324	
S/C 224/50V(X7R) 10% SMD 1206	YAGEO	N.D.	N.D.	N.D.	N.D.	N.D.	N.D.	KA_2009_11324	
S/C 474/25V(X7R) 10% SMD 0805	YAGEO	N.D.	N.D.	N.D.	N.D.	N.D.	N.D.	KA_2009_11324	
S/C 475/25V(X7R) 10% SMD 1206	YAGEO	N.D.	N.D.	N.D.	N.D.	N.D.	N.D.	KA_2009_11324	
S/C 224/50V(X7R) 10% SMD 0805	YAGEO	N.D.	N.D.	N.D.	N.D.	N.D.	N.D.	KA_2009_11324	
S/C 472/200V(X7R) 10% SMD 0805	YAGEO	N.D.	N.D.	N.D.	N.D.	N.D.	N.D.	KA_2009_11324	
S/C 222/50V(X7R) 10% SMD 0805	YAGEO	N.D.	N.D.	N.D.	N.D.	N.D.	N.D.	KA_2009_11324	
S/C 472/50V(X7R) 10% SMD 0805	YAGEO	N.D.	N.D.	N.D.	N.D.	N.D.	N.D.	KA_2009_11324	
S/C 471/50V(X7R) 10% SMD 0805	YAGEO	N.D.	N.D.	N.D.	N.D.	N.D.	N.D.	KA_2009_11324	
S/C 221/50V(X7R) 10% SMD 0805	YAGEO	N.D.	N.D.	N.D.	N.D.	N.D.	N.D.	KA_2009_11324	
S/C 105/25V(X7R) 10% SMD 0805	YAGEO	N.D.	N.D.	N.D.	N.D.	N.D.	N.D.	KA_2009_11324	
S/C 101/50V(NPO) 5% SMD 0805	YAGEO	N.D.	N.D.	N.D.	N.D.	N.D.	N.D.	KA_2009_11345	
S/C 475/16V(X5R) 10% SMD 1206	WALSIN	N.D.	8	N.D.	N.D.	N.D.	N.D.	CE_2007_64632D	
S/C 226/16V(X7R) 10% SMD 1210	TDK	N.D.	N.D.	N.D.	N.D.	N.D.	N.D.	TWNC00104394	
T/C 4.7UF/20V SMD A-TYPE	AVX	N.D.	6	N.D.	N.D.	N.D.	N.D.	CE_2008_21496~19508	
C/C-Y 222/250V TDK CS系列 Y2	TDK	N.D.	63	N.D.	N.D.	N.D.	N.D.	TWNC00105984	
C/C 222/1KV	永銳(EASE)	N.D.	18	N.D.	N.D.	N.D.	N.D.	CE_2007_B1906	
C/C-Y 472/250V TDK CS系列 Y2	TDK	N.D.	63	N.D.	N.D.	N.D.	N.D.	TWNC00105984	
C/C-Y 332/250V TDK CD系列 Y1	TDK	N.D.	63	N.D.	N.D.	N.D.	N.D.	TWNC00105984	
E/C 1000UF/6.3V (8 φ x11.5) YXG	RUBYCON	N.D.	18	N.D.	Negative	N.D.	N.D.	CE_2007_85971A	
E/C 22UF/25V (4 φ x7mm)	RUBYCON	N.D.	4	N.D.	N.D.	N.D.	N.D.	SH8142216_CHEM	
E/C 2200UF/16V (10 φ x25)低内阻	NIPPON	N.D.	N.D.	N.D.	N.D.	N.D.	N.D.	SONY GP	
E/C 1000UF/16V (8 φ x20) KY系列	NIPPON	N.D.	N.D.	N.D.	N.D.	N.D.	N.D.	SONY GP	
E/C 100UF/25V (6.3 φ x11mm) KY	NIPPON	N.D.	N.D.	N.D.	N.D.	N.D.	N.D.	SONY GP	
E/C 4.7UF/50V (4 φ x7mm) MH7	RUBYCON	N.D.	18	N.D.	Negative	N.D.	N.D.	CE_2007_85971A	
E/C 220UF/420V (30 φ x25mm) HU	HITACHI	N.D.	13	N.D.	N.D.	N.D.	N.D.	AC-1178	
CS/C 270UF/16V (8 φ x12)PSC系列	NIPPON	N.D.	290	N.D.	N.D.	N.D.	N.D.	33905248-01M-003	
E/C 47UF/50V (6.3 φ x11mm) KMG	NIPPON	N.D.	N.D.	N.D.	N.D.	N.D.	N.D.	SONY GP	
CS/C 470UF/6.3V (8 φ x8) UPS	CHINSAN	N.D.	12	N.D.	N.D.	N.D.	N.D.	CE_2008_60247	
INDUCTOR EMR-101(8UH)	晁欣(CHIEF)	N.D.	55	N.D.	N.D.	N.D.	N.D.	refer to transformer	

MODEL : C2W-5620V

Description	Supplier	Cd (ppm)	Pb (ppm)	Hg(ppm)	Cr VI(ppm)	PBB(ppm)	PBDE(ppm)	Test report No.	Exemption
INDUCTOR BS43-330K 33uH SMD	晁欣(CHIEF)	N.D.	364	N.D.	N.D.	N.D.	861	GZ0704056610_CHEM	
INDUCTOR R6x10 (0.5uH)	立杰(LI CHIEH)	N.D.	33	N.D.	N.D.	N.D.	N.D.	refer to transformer	
INDUCTOR EMR-232 (77935x2)	立杰(LI CHIEH)	N.D.	307	N.D.	N.D.	N.D.	N.D.	refer to transformer	
INDUCTOR EMR-287 (CS234125)	立杰(LI CHIEH)	N.D.	266	N.D.	N.D.	N.D.	N.D.	refer to transformer	
INDUCTOR EMR-290 (HF080125-2)	金益宏	N.D.	N.D.	N.D.	N.D.	N.D.	N.D.	refer to transformer	
INDUCTOR EMR-292 (CS270125E18)	立杰(LI CHIEH)	N.D.	266	N.D.	N.D.	N.D.	N.D.	refer to transformer	
INDUCTOR EMR-336 (T25x15x13-C)	立杰(LI CHIEH)	N.D.	63.4	N.D.	N.D.	N.D.	N.D.	refer to transformer	
VARISTOR SIOV S14K300/EPCOS	NIPPON	N.D.	N.D.	N.D.	N.D.	N.D.	N.D.	SONY GP	
TRANSFORMER EMT-225 (EE-8)	立杰(LI CHIEH)	N.D.	307	N.D.	N.D.	N.D.	N.D.	refer to transformer	
TRANSFORMER EMT-242 (EE-8.3)	立杰(LI CHIEH)	N.D.	307	N.D.	N.D.	N.D.	N.D.	refer to transformer	
TRANSFORMER EMT-250(V1)	立杰(LI CHIEH)	N.D.	62.8	N.D.	N.D.	N.D.	N.D.	refer to transformer	
TRANSFORMER EMT-251 (V2)	晁欣(CHIEF)	N.D.	364	N.D.	N.D.	N.D.	861	GZ0704056610_CHEM	
RELAY LMR1H-12D (16A/250V)	RAYEX	N.D.	13	N.D.	N.D.	N.D.	N.D.	CE_2008_15394	
TERM T250 PIN (公座)	品固(PINGOOD)	N.D.	17	N.D.	Negative	N.D.	N.D.	CE_2007_95060	
LEADER FRAME SIMC PS-2-A2.54mm	純通MIN.DWAVES	N.D.	29	N.D.	Negative	*	*	CE_2008_11013-30799	
LEADER FRAME90度PK 2.54-1.0-11	純通MIN.DWAVES	N.D.	29	N.D.	Negative	*	*	CE_2008_11013-30799	
PIN HEADER 2.54m/m-1x4PIN-90°	友歆(YOUXIN)	N.D.	14	N.D.	N.D.	N.D.	N.D.	CE_2007_B4310A	
BASE 2.54-2P-180°	亞式(ALEX)	N.D.	N.D.	N.D.	N.D.	N.D.	N.D.	CE_2007_40515	
BASE 2.54-3P-180°	亞式(ALEX)	N.D.	N.D.	N.D.	N.D.	N.D.	N.D.	CE_2007_40515	
BASE 1.25-5P-180°P125I Series	WAH LEE	N.D.	54	N.D.	N.D.	N.D.	N.D.	CE_2007_61407	
BASE 1.25-2P-180°P125I Series	WAH LEE	N.D.	54	N.D.	N.D.	N.D.	N.D.	CE_2007_61407	
鍍錫線 60m/m 1ψ	承洧(CHERNG WEEI)	N.D.	25	N.D.	N.D.	N.D.	N.D.	CE_2008_25374	
熱縮套管 4 ϕ x230m/m(125°C)	HAMBURG	N.D.	N.D.	N.D.	N.D.	N.D.	N.D.	CE_2008_38467	
熱縮套管 7 ϕ x15m/m(125°C)	HAMBURG	N.D.	N.D.	N.D.	N.D.	N.D.	N.D.	CE_2008_38467	
熱縮套管 7 ϕ x25m/m(125°C)	HAMBURG	N.D.	N.D.	N.D.	N.D.	N.D.	N.D.	CE_2008_38467	
熱縮套管 12 ϕ x15m/m(125°C)	HAMBURG	N.D.	N.D.	N.D.	N.D.	N.D.	N.D.	CE_2008_38467	
熱縮套管 1.5 ϕ x20m/m(125°C)	HAMBURG	N.D.	N.D.	N.D.	N.D.	N.D.	N.D.	CE_2008_38467	
熱縮套管 1 ϕ x10m/m(125°C)	HAMBURG	N.D.	N.D.	N.D.	N.D.	N.D.	N.D.	CE_2008_38467	
熱縮套管 1 ϕ x20m/m(125°C)	HAMBURG	N.D.	N.D.	N.D.	N.D.	N.D.	N.D.	CE_2008_38467	
熱縮套管 1 ϕ x30m/m(125°C)	HAMBURG	N.D.	N.D.	N.D.	N.D.	N.D.	N.D.	CE_2008_38467	
透明套管鐵氟龍材質1.34 ϕ x4.6mm	FLUOTECH	N.D.	N.D.	N.D.	N.D.	N.D.	N.D.	CE_2009_31674	
BEAD CORE K5B T 4x2x2	鈞寶(KING)	N.D.	N.D.	N.D.	N.D.	N.D.	N.D.	CE_2008_66280	
SHARING PLANE 45x30 L:60+MYLAR	立杰(LI CHIEH)	N.D.	13.7	N.D.	N.D.	*	*	CE_2006_C3112A	
公座(FILTER)15SS1-LHG-Q 15A	HIGH&LOW	3	550	N.D.	N.D.	N.D.	N.D.	THJ0045793	
SLOT A-007-56PIN 180° 孔距1.0	啓賢(KEMAX)	N.D.	18	N.D.	N.D.	N.D.	N.D.	CE_2007_36446	
FAN 3828 F3828B12HBHB+2.54-3P	奇鈺(AVC)	N.D.	69.9	N.D.	N.D.	N.D.	N.D.	refer to AVC informaiton	
保險絲 UL/CSA 15A/250V GBP-A	功得(CONQUER)	N.D.	34	N.D.	N.D.	N.D.	N.D.	CE_2007_85258	
PCB 060102NCP1653 REV:A01	集琳(LIN GENIUS)	N.D.	N.D.	N.D.	N.D.	N.D.	N.D.	CE_2007_56652	
PCB 070411 ACPWBM(V2)	元廣(YUANGUAN)	N.D.	279	N.D.	N.D.	N.D.	N.D.	CE_2007_C1684	
PCB CSB12 REV:A1	元廣(YUANGUAN)	N.D.	279	N.D.	N.D.	N.D.	N.D.	CE_2007_C1684	
PCB 080707 BOOST V1	元廣(YUANGUAN)	N.D.	279	N.D.	N.D.	N.D.	N.D.	B6849+85597	
PCB VRB V1	元廣(YUANGUAN)	N.D.	245	N.D.	N.D.	N.D.	N.D.	B6849-C4421	

MODEL : C2W-5620V

Description	Supplier	Cd (ppm)	Pb (ppm)	Hg(ppm)	Cr VI(ppm)	PBB(ppm)	PBDE(ppm)	Test report No.	Exemption
PCB 090630 T1W-V (V1)	元廣(YUANGUAN)	N.D.	245	N.D.	N.D.	N.D.	N.D.	B6849-C4421	
PCB 090630 OF5B-SO8 (V1)	元廣(YUANGUAN)	N.D.	245	N.D.	N.D.	N.D.	N.D.	B6849-C4421	
PCB 090630 T1W2-BV (V1)	元廣(YUANGUAN)	N.D.	245	N.D.	N.D.	N.D.	N.D.	B6849-C4421	
PCB 090310 DD40A-SO8 (V1)	元廣(YUANGUAN)	N.D.	245	N.D.	N.D.	N.D.	N.D.	B6849-C4421	
SCREW 細牙M3x4 埋頭(薄) NI	同利(TONG LI)	N.D.	N.D.	N.D.	Negative	*	*	CE_2009_22076A	
SCREW 細牙M3x6 埋頭 Ni	同利(TONG LI)	N.D.	N.D.	N.D.	Negative	*	*	CE_2008_56552	
SCREW 細牙 M3x6 截錐頭	同利(TONG LI)	N.D.	N.D.	N.D.	Negative	*	*	CE_2009_22076A	
SCREW 細牙 M3x6 截錐頭+SPW Ni	龍雨(LONGAN YUE)	N.D.	N.D.	N.D.	Negative	*	*	CE_2008_56552	
SCREW 細牙M3x8 截錐頭+SPW	同利(TONG LI)	N.D.	N.D.	N.D.	Negative	*	*	CE_2009_22076A	
SCREW 一字槽細牙/鍍鎳M3x9	同利(TONG LI)	N.D.	N.D.	N.D.	Negative	*	*	CE_2009_22076A	
SCREW 細牙M3x12 截錐頭+SPW	同利(TONG LI)	N.D.	N.D.	N.D.	Negative	*	*	CE_2009_22076A	
SCREW 細牙M3x14 截錐頭+SPW	同利(TONG LI)	N.D.	N.D.	N.D.	Negative	*	*	CE_2009_22076A	
SCREW 細牙 M3x35 截錐頭 Ni	同利(TONG LI)	N.D.	N.D.	N.D.	Negative	*	*	CE_2009_22076A	
SCREW 粗牙 #6x4 埋頭 Ni	同利(TONG LI)	N.D.	N.D.	N.D.	Negative	*	*	CE_2009_22076A	
SCREW 粗牙 #6x6 埋頭 Ni	同利(TONG LI)	N.D.	N.D.	N.D.	Negative	*	*	CE_2009_22076A	
SCREW 粗牙(自攻)M3x6截錐厚五彩	同利(TONG LI)	N.D.	N.D.	N.D.	Negative	*	*	CE_2009_22076A	
SCREW 粗牙(自攻) M4x10 埋頭 Ni	同利(TONG LI)	N.D.	N.D.	N.D.	Negative	*	*	CE_2009_22076A	
SCREW 細牙 M2x5 圓頭 Ni	同利(TONG LI)	N.D.	N.D.	N.D.	Negative	*	*	CE_2009_22076A	
NUT M3x0.5 Ni	同利(TONG LI)	N.D.	N.D.	N.D.	Negative	*	*	CE_2009_22076A	
NUT M4x0.7 加華司 NI	同利(TONG LI)	N.D.	N.D.	N.D.	Negative	*	*	CE_2009_22076A	
WASHER M3 SPRING NI	同利(TONG LI)	N.D.	N.D.	N.D.	Negative	*	*	CE_2009_22076A	
E型扣環 ϕ 2 鍍鎳	同利(TONG LI)	N.D.	N.D.	N.D.	N.D.	*	*	(6207)193-0222	
HEAT SINK 30x32mm (1孔) 鋁擠型	歲誠(WERE CHEN)	N.D.	12	N.D.	Negative	N.D.	N.D.	CE_2008_75259	
HEAT SINK 13x31mm T:1.5 銅板	明達 (M.D)	N.D.	8	N.D.	N.D.	*	*	CE_2007_41052	
HEAT SINK 27.7x2.8mm黃銅板鍍錫	偉錠(WELY TING)	N.D.	N.D.	N.D.	N.D.	N.D.	N.D.	KC_2007_80080	
HEAT SINK 20.4x36mm 黃銅板鍍錫	偉錠(WELY TING)	N.D.	N.D.	N.D.	N.D.	N.D.	N.D.	KC_2007_80080	
HEAT SINK 31.8x14.5mm 鋁板	偉錠(WELY TING)	N.D.	N.D.	N.D.	N.D.	N.D.	N.D.	KC_2007_80080	
HEAT SINK 84x29.4mm (5孔)	偉錠(WELY TING)	N.D.	N.D.	N.D.	N.D.	N.D.	N.D.	KC_2007_80080	
HEAT SINK 84x32.5mm 黃銅板鍍錫	偉錠(WELY TING)	N.D.	N.D.	N.D.	N.D.	N.D.	N.D.	KC_2007_80080	
HEAT SINK 57x31.5mm 黃銅板鍍錫	偉錠(WELY TING)	N.D.	N.D.	N.D.	N.D.	N.D.	N.D.	KC_2007_80080	
HEAT SINK 53x33mm (5孔) 鋁擠型	偉錠(WELY TING)	N.D.	N.D.	N.D.	N.D.	N.D.	N.D.	KC_2007_80080	
HEAT SINK 74x45.5mm T:1.0	偉錠(WELY TING)	N.D.	N.D.	N.D.	N.D.	N.D.	N.D.	KC_2007_80080	
BRACKET (2) R2G 固定架(2)	馨錦(SHING JING)	N.D.	N.D.	N.D.	Negative	*	*	CE_2008_C6383-9_30941	
P/S HOLDER 把手(M1Z)	聯伙 (LEN BEE)	N.D.	27	N.D.	N.D.	*	*	CE_2007_60235	
SIDE COVER 背板 (T1W2-V專用)	馨錦(SHING JING)	N.D.	N.D.	N.D.	Negative	*	*	CE_2008_C6383-9_30941	
P/S COVER 前面板 (C2W-R 用)	馨錦(SHING JING)	N.D.	N.D.	N.D.	Negative	*	*	CE_2008_C6383-9_30941	
BRACKET 固定架1 (M2W用)	勤研(CIN YAN)	N.D.	N.D.	N.D.	N.D.	*	*	CE_2008_42512	
BRACKET M1Z 固定片2	聯伙 (LEN BEE)	N.D.	N.D.	N.D.	N.D.	*	*	CE_2007_31229	
BRACKET 固定片支架 FOR R2W	新輪 (SHIN LUEN)	N.D.	N.D.	N.D.	N.D.	*	*	CE_2007_B2556	
CASE 下蓋 T1W-3A00V用	聯伙 (LEN BEE)	N.D.	N.D.	N.D.	N.D.	*	*	CE_2007_31229	
COVER 上蓋 MT1W-3A00V用	馨錦(SHING JING)	N.D.	N.D.	N.D.	N.D.	*	*	CE_2008_C6383	
CHASSIS 主體 (T1W2-V用)	馨錦(SHING JING)	N.D.	N.D.	N.D.	N.D.	*	*	CE_2008_C6383	

MODEL : C2W-5620V

Description	Supplier	Cd (ppm)	Pb (ppm)	Hg(ppm)	Cr VI(ppm)	PBB(ppm)	PBDE(ppm)	Test report No.	Exemption
單心線 UL1007#22 80mm x6x6-B	韻華(YUN HUA)	N.D.	N.D.	N.D.	N.D.	N.D.	N.D.	refer to cable	
單條連接線1015#16 130mm+T250黑	韻華(YUN HUA)	N.D.	N.D.	N.D.	N.D.	N.D.	N.D.	refer to cable	
單條連接線1015#16 130mm+T250白	韻華(YUN HUA)	N.D.	N.D.	N.D.	N.D.	N.D.	N.D.	refer to cable	
地線 UL1015#14 60mmx10+4.3-GY	韻華(YUN HUA)	N.D.	N.D.	N.D.	N.D.	N.D.	N.D.	refer to cable	
排線2.54-1B/2R 併/絞 #22 700mm	韻華(YUN HUA)	N.D.	28.5	N.D.	N.D.	N.D.	N.D.	refer to cable	
排線(H553M)5P-1PU/2W/4B 700mm	韻華(YUN HUA)	N.D.	28.5	N.D.	N.D.	N.D.	N.D.	refer to cable	
排線8P 1-4B/5-8Y 1007#18 630mm	韻華(YUN HUA)	N.D.	N.D.	N.D.	N.D.	N.D.	N.D.	refer to cable	
排線/2.54-1B/2R 1007#22 270mm	韻華(YUN HUA)	N.D.	N.D.	N.D.	N.D.	N.D.	N.D.	refer to cable	
排線+2.54LED+TUBE加工#22 270mm	韻華(YUN HUA)	N.D.	2	N.D.	N.D.	N.D.	N.D.	refer to cable	
排線2.54-1B/2Y 併絞#22 690mm	韻華(YUN HUA)	N.D.	28.5	N.D.	N.D.	N.D.	N.D.	refer to cable	
排線8P(4P+4P專利)1007#18 640mm	韻華(YUN HUA)	N.D.	28.5	N.D.	N.D.	N.D.	N.D.	refer to cable	
排線1.25-2P(H125)-1PU/2W 50mm	韻華(YUN HUA)	N.D.	28.5	N.D.	N.D.	N.D.	N.D.	refer to cable	
排線24P R ₂ O併#22 730mm T1W2-V	韻華(YUN HUA)	N.D.	28.5	N.D.	N.D.	N.D.	N.D.	refer to cable	
排線#18 R:690 O:700 680mm SATA	韻華(YUN HUA)	N.D.	28.5	N.D.	N.D.	N.D.	N.D.	refer to cable	
大併大 #18/18 R:490 480+150mm	韻華(YUN HUA)	N.D.	28.5	N.D.	N.D.	N.D.	N.D.	refer to cable	
大併小 R:340 #18/22 330+150mm	韻華(YUN HUA)	N.D.	28.5	N.D.	N.D.	N.D.	N.D.	refer to cable	
大併大 R:340 #18/18 330+150mm	韻華(YUN HUA)	N.D.	28.5	N.D.	N.D.	N.D.	N.D.	refer to cable	
大併小 R:440 #18/22 430+150mm	韻華(YUN HUA)	N.D.	28.5	N.D.	N.D.	N.D.	N.D.	refer to cable	
束線帶 YJ-80	品固(PINGOOD)	N.D.	N.D.	N.D.	N.D.	N.D.	N.D.	CE_2008_B3399	
束線帶 YJ-142	品固(PINGOOD)	N.D.	N.D.	N.D.	N.D.	N.D.	N.D.	CE_2008_B3399	
活動護線套 US-1125	品固(PINGOOD)	N.D.	N.D.	N.D.	N.D.	N.D.	N.D.	CE_2008_B3399	
P.C.板間隔柱 DCBS-3M	品固(PINGOOD)	N.D.	N.D.	N.D.	N.D.	N.D.	N.D.	CE_2008_B3399	
熱敏電阻座 HU-07F-PBW	品固(PINGOOD)	N.D.	N.D.	N.D.	N.D.	N.D.	N.D.	CE_2008_B3399	
導光棒/透明PC3x37.5mm(R2W用)	安生(ANSONN)	N.D.	N.D.	N.D.	N.D.	N.D.	N.D.	KA_2007_33208	
絕緣片 塑膠 20x20mm	南亞(NAN YA)	N.D.	N.D.	N.D.	N.D.	N.D.	N.D.	CE_2008_C2754	
絕緣片 矽膠 18x13x0.2mm TO-220	PIONEER	N.D.	N.D.	N.D.	N.D.	N.D.	N.D.	CE_2007_C0243	
絕緣片 矽膠 65x15x1.0mm	PIONEER	N.D.	N.D.	N.D.	N.D.	N.D.	N.D.	CE_2007_C0243	
絕緣片 31x31x0.2t FR-4	南亞(NAN YA)	N.D.	N.D.	N.D.	N.D.	N.D.	N.D.	CE_2008_C2754	
絕緣片 矽膠 95x35x1.0mm	PIONEER	N.D.	N.D.	N.D.	N.D.	N.D.	N.D.	CE_2007_C0243	
絕緣片 24x30x0.254mm FR-1	權祐(SABIC)	N.D.	48	N.D.	N.D.	N.D.	N.D.	SH8128325_CHEM	
絕緣片 矽膠 25x25x1.5mm	PIONEER	N.D.	N.D.	N.D.	N.D.	N.D.	N.D.	CE_2007_C0243	
絕緣片 矽膠 25x25x1.0mm	PIONEER	N.D.	N.D.	N.D.	N.D.	N.D.	N.D.	CE_2007_C0243	
絕緣片 矽膠 35x20x1.5mm	PIONEER	N.D.	N.D.	N.D.	N.D.	N.D.	N.D.	CE_2007_C0243	
絕緣片 225x177.5x0.254mm FR-1	權祐(SABIC)	N.D.	48	N.D.	N.D.	N.D.	N.D.	SH8128325_CHEM	
絕緣片 矽膠 28x10x0.5mm	PIONEER	N.D.	N.D.	N.D.	N.D.	N.D.	N.D.	CE_2007_C0243	
絕緣粒6x3.55x2.95m/m→602V.0	品固(PINGOOD)	N.D.	N.D.	N.D.	N.D.	N.D.	N.D.	CE_2008_B3399	
CARTON 410x175x215mm R2W用 1入	南北(NAN BEI)	N.D.	9	N.D.	N.D.	N.D.	N.D.	CE_2008_A0701	
CARTON 440x395x480mm R2W用 4入	南北(NAN BEI)	N.D.	9	N.D.	N.D.	N.D.	N.D.	CE_2008_A0701	
MODEL EMACS NO-SAFETY (06-026)	銘章(MING ZHANG)	N.D.	N.D.	N.D.	N.D.	N.D.	N.D.	CE_2008_12352A-48398	
MODEL EMACS NO-SAFETY 46x30mm	銘章(MING ZHANG)	N.D.	N.D.	N.D.	N.D.	N.D.	N.D.	CE_2008_12352A-48398	
LABEL-ROUND QC PASSED	銘章(MING ZHANG)	N.D.	N.D.	N.D.	N.D.	N.D.	N.D.	TLSMB-2009	
LABEL HI POT OK (藍底黑字)	銘章(MING ZHANG)	N.D.	N.D.	N.D.	N.D.	N.D.	N.D.	TLSMB-2009	

MODEL : C2W-5620V

Description	Supplier	Cd (ppm)	Pb (ppm)	Hg(ppm)	Cr VI(ppm)	PBB(ppm)	PBDE(ppm)	Test report No.	Exemption
LABEL/06-005 CAUTION 長方形	銘章(MING ZHANG)	N.D.	N.D.	N.D.	N.D.	N.D.	N.D.	TLSMB-2009	

MODEL : C2W-5620V

Description	Supplier	Cd (ppm)	Pb (ppm)	Hg(ppm)	Cr VI(ppm)	PBB(ppm)	PBDE(ppm)	Test report No.	Exemption
IC L7912CV (SGS)	ST	N.D.	1720	N.D.	Negative	N.D.	N.D.	CE_2007_80662	LEAD-1
MOSFET FQPF3N80C (3A/800V)	FAIRCHILD	N.D.	7940	N.D.	N.D.	N.D.	N.D.	CE_2009_22654	LEAD-1
SCHOTTKY EC31QS03L(3A/30V) SMD	NIHON	N.D.	24500	N.D.	N.D.	N.D.	N.D.	CE_2009_14840	LEAD-1
SCHOTTKY BAS85 (200mA/30V) SMD	SIRECTIFIER	N.D.	1860	N.D.	N.D.	N.D.	N.D.	SHAH0010484801	LEAD-1
SCHOTTKY 95SQ015 (9A/15V)	SIRECTIFIER	N.D.	1860	N.D.	N.D.	N.D.	N.D.	SHAH0010484801	LEAD-1
SCHOTTKY MBR2060CT (20A/60V)	SIRECTIFIER	N.D.	1860	N.D.	N.D.	N.D.	N.D.	SHAH0010484801	LEAD-1
SCHOTTKY BAT54C (200mA/30V)SMD	SIRECTIFIER	N.D.	1860	N.D.	N.D.	N.D.	N.D.	SHAH0010484801	LEAD-1
FAST S3L20U 3A/200V DO-201AD	SHINDENGEN	N.D.	9980	N.D.	N.D.	N.D.	N.D.	CE_2008_94703	LEAD-1
FAST STTH12R06FP 12A/600V	ST	N.D.	2300	N.D.	N.D.	N.D.	N.D.	CE_2007_80663	LEAD-1
BUZZER OBO-15210G	克霖(OBO)	N.D.	168807	N.D.	N.D.	*	*	B210180009	LEAD-1
IC SOCKET 單排 17PIN	承洧	22	27045	N.D.	N.D.	N.D.	289	CE_2007_44208-GZ0705076679_CHEM	LEAD-2
IC SOCKET 單排 13PIN	承洧	22	27045	N.D.	N.D.	N.D.	289	CE_2007_44208-GZ0705076679_CHEM	LEAD-2
DIODE 1SS355 SMD UMD2 SOD-323	ROHM	<2	409000	<2	<2	<5	<5	Data-B200020016	LEAD-4
DIODE-ZENER HZK11ATR-S-E-Q SMD	RENESAS	N.D.	147000	N.D.	N.D.	N.D.	N.D.	KA_2008_91899	LEAD-4
DIODE-ZENER RKZ6B1 SMD (LLD)	RENESAS	N.D.	87300	N.D.	N.D.	N.D.	N.D.	KA_2008_71475	LEAD-4
DIODE-ZENER RKZ4A2 SMD (LLD)	RENESAS	N.D.	87300	N.D.	N.D.	N.D.	N.D.	KA_2008_71475	LEAD-4

Lead-1: Lead in high melting temperature type solders (i.e. lead-based alloys containing 85 % by weight or more lead). (2005/747/EC)

Lead-2: Lead in solders for servers, storage and storage array systems, network infrastructure equipment for switching, signalling, transmission as well as network management for telecommunications.(2005/747/EC)

Lead-3:Lead in electronic ceramic parts (e.g. piezoelectronic devices). (2005/747/EC)

Lead-4: Lead in glass of cathode ray tubes, electronic components and fluorescent tubes. (2002/95/EC)

Lead-5:Lead as an alloying element in steel containing up to 0.35% lead by weight, aluminium containing up to 0.4% lead by weight and as a copper alloy containing up to 4% lead by weight. (2002/95/EC)

使用機種	數量(入)	淨重(KG)	毛重(KG)	紙箱尺寸(mm)
C2W-5620V	1	4.21		410x175x215
C2W-5820V	1	4.21		410x175x215
G1W2-5960V3V	4			440x395x480
G1W2-5960V3V	1	4.52		410x175x215
H1M-5707V	9			560x360x351
H1M-5707V	1	1.92		
M1S2-5500V4H	4		15.00	570x415x255
M1S2-5500V4H	1	3.50		550x200x112
M1Z3-5A45V3V	2		11.5	450x385x318
M1Z3-5A45V3V	1	5.09		435x177x280
MRM-6600P	1		5.60	400x225x180
MRW-6420P	4	20.00		567x518x220
MRW-6420P	1	4.50		270x245x180
MX3-6600P	1	5.00	5.40	421x236x164
P1H-5500V	10		17.70	565x315x265
P1H-5500V	1	1.41		
P1M-6400P	10		17.90	565x315x265
P1M-6400P	1	1.50		
P2G-6510P	10	26.76		506x472x252
P2G-6510P	1	2.33		
PSL-6C00V	4		16.5	445x425x295
PSL-6C00V	1	3.68		
R2W-6500P	1	4.90		410x175x215
R3G-6650P	1		5.90	409x154x196

