

SUPERO®

SC418 CHASSIS SERIES

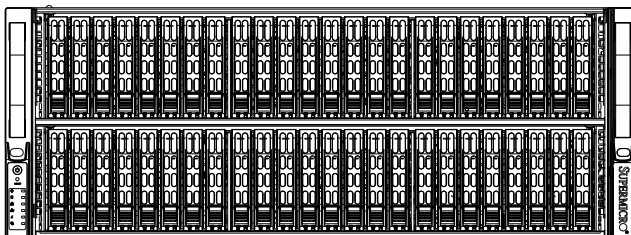

SC418E16-R1K62B
SC418E16-R1K62B2

USER'S MANUAL

1.0b

The information in this User's Manual has been carefully reviewed and is believed to be accurate. The vendor assumes no responsibility for any inaccuracies that may be contained in this document, makes no commitment to update or to keep current the information in this manual, or to notify any person or organization of the updates. **Please Note: For the most up-to-date version of this manual, please see our web site at www.supermicro.com.**

Super Micro Computer, Inc. ("Supermicro") reserves the right to make changes to the product described in this manual at any time and without notice. This product, including software and documentation, is the property of Supermicro and/or its licensors, and is supplied only under a license. Any use or reproduction of this product is not allowed, except as expressly permitted by the terms of said license.

IN NO EVENT WILL SUPERMICRO BE LIABLE FOR DIRECT, INDIRECT, SPECIAL, INCIDENTAL, SPECULATIVE OR CONSEQUENTIAL DAMAGES ARISING FROM THE USE OR INABILITY TO USE THIS PRODUCT OR DOCUMENTATION, EVEN IF ADVISED OF THE POSSIBILITY OF SUCH DAMAGES. IN PARTICULAR, SUPERMICRO SHALL NOT HAVE LIABILITY FOR ANY HARDWARE, SOFTWARE, OR DATA STORED OR USED WITH THE PRODUCT, INCLUDING THE COSTS OF REPAIRING, REPLACING, INTEGRATING, INSTALLING OR RECOVERING SUCH HARDWARE, SOFTWARE, OR DATA.

Any disputes arising between manufacturer and customer shall be governed by the laws of Santa Clara County in the State of California, USA. The State of California, County of Santa Clara shall be the exclusive venue for the resolution of any such disputes. Super Micro's total liability for all claims will not exceed the price paid for the hardware product.

California Best Management Practices Regulations for Perchlorate Materials: This Perchlorate warning applies only to products containing CR (Manganese Dioxide) Lithium coin cells. "Perchlorate Material-special handling may apply. See www.dtsc.ca.gov/hazardouswaste/perchlorate"

WARNING: Handling of lead solder materials used in this product may expose you to lead, a chemical known to the State of California to cause birth defects and other reproductive harm.

Manual Revision 1.0b
Release Date: January 27, 2014

Unless you request and receive written permission from Super Micro Computer, Inc., you may not copy any part of this document.

Information in this document is subject to change without notice. Other products and companies referred to herein are trademarks or registered trademarks of their respective companies or mark holders.

Copyright © 2014 by Super Micro Computer, Inc.
All rights reserved.

Printed in the United States of America

Preface

About This Manual

This manual is written for professional system integrators and PC technicians. It provides information for the installation and use of the SC418 chassis. Installation and maintenance should be performed by experienced technicians only.

This manual lists compatible parts available when this document was published. Always refer to the our web site for updates on supported parts and configurations.

Manual Organization

Chapter 1 Introduction

The first chapter provides a checklist of the main components included with this chassis and describes the main features of the SC418 chassis. This chapter also includes contact information.

Chapter 2 Warning Statements for AC Systems

This chapter lists warnings, precautions, and system safety. It recommended that you thoroughly familiarize yourself installing and servicing this chassis safety precautions.

Chapter 3 System Interface

Refer to this chapter for details on the system interface, which includes the functions and information provided by the control panel on the chassis as well as other LEDs located throughout the system.

Chapter 4 Chassis Setup and Maintenance

Follow the procedures given in this chapter when installing, removing, or reconfiguring your chassis.

Chapter 5 Rack Installation

Refer to this chapter for detailed information on chassis rack installation. You should follow the procedures given in this chapter when installing, removing or reconfiguring your chassis into a rack environment.

This section lists compatible cables, power supply specifications, and compatible backplanes. Not all compatible backplanes are listed. Refer to our web site for the latest compatible backplane information.

Appendix A Cables and Hardware

This section provides information on cabling, and other hardware which is compatible with your chassis. For complete information on supported cables and hardware, refer to the Supermicro web site at www.supermicro.com.

Appendix B Power Supply Specifications

This chapter lists the specifications of the power supplies provided with your chassis. For additional information, refer to the Supermicro website at www.supermicro.com.

Appendix C BPN-SAS2-216EL Backplane Specifications

Appendices C contains detailed specifications on the BPN-SAS2-216EL1 and BPN-SAS2-216EL2 backplanes. Additional information can be found on the Supermicro web site at www.supermicro.com.

Contents

Chapter 1 Introduction

1-1	Overview	1-1
1-2	Shipping List.....	1-1
	Part Numbers	1-1
1-3	Where to get Replacement Components.....	1-2
1-4	Contacting Supermicro.....	1-3
1-5	Returning Merchandise for Service.....	1-4

Chapter 2 Standardized Warning Statements for AC Systems

2-1	About Standardized Warning Statements	2-1
	Warning Definition	2-1
	Installation Instructions.....	2-4
	Circuit Breaker	2-5
	Power Disconnection Warning.....	2-6
	Equipment Installation	2-8
	Restricted Area.....	2-9
	Battery Handling.....	2-10
	Redundant Power Supplies	2-12
	Backplane Voltage	2-13
	Comply with Local and National Electrical Codes.....	2-14
	Product Disposal	2-15
	Hot Swap Fan Warning.....	2-16
	Power Cable and AC Adapter	2-18

Chapter 3 System Interface

3-1	Overview	3-1
3-2	Control Panel Buttons	3-2
3-3	Control Panel LEDs	3-2
	Overheating.....	3-4
3-4	Drive Carrier LEDs.....	3-4
3-5	Power Supply LEDs	3-4

Chapter 4 Chassis Setup and Maintenance

4-1	Overview	4-1
4-2	Removing Power from the System	4-1
4-3	Removing the Chassis Top Cover	4-2
4-4	Installing and Removing Hard Drives	4-3
4-5	Installing the Motherboard	4-6
	I/O Shield	4-6
	Permanent and Optional Standoffs.....	4-7
	Installing Heatsinks on the Motherboard	4-10
	PCI Slot Setup	4-11
4-6	Installing the Air Shroud.....	4-12
	Checking the Airflow	4-15
	Setup Tasks Complete	4-15
4-7	System Fans	4-16
	Replacing Internal System Fans.....	4-16
	Installing and Removing External System Fans.....	4-17
4-8	Power Supply	4-19
4-9	Changing the Power Distributor Board.....	4-21
4-10	Configuring the Peripheral Drawer.....	4-25
	Removing the Peripheral Drawer.....	4-26
	Installing 2.5" and 3.5" Drives in the Peripheral Drawer	4-27
	Installing Peripheral Devices in the Peripheral Drawer	4-28
	Removing Peripheral Devices from the Peripheral Drawer.....	4-29
	Routing Cables in the Peripheral Drawer	4-30
4-11	Accessing the Backplane.....	4-31

Chapter 5 Rack Installation

5-1	Unpacking the System.....	5-1
5-2	Preparing for Setup.....	5-1
	Choosing a Setup Location.....	5-1
5-3	Warnings and Precautions.....	5-2
	Rack Precautions	5-2
	General Server Precautions.....	5-2
5-4	Rack Mounting Considerations	5-3
	Ambient Operating Temperature	5-3
	Reduced Airflow	5-3
	Mechanical Loading	5-3
	Circuit Overloading.....	5-3
	Reliable Ground	5-3

5-5	Rack Mounting Instructions.....	5-4
	Identifying the Sections of the Rack Rails.....	5-4
	Locking Tabs.....	5-5
	Releasing the Inner Rail.....	5-5
	Installing The Inner Rails on the Chassis.....	5-6
	Installing the Outer Rails on the Rack.....	5-7
	Standard Chassis Installation.....	5-8
	Optional Quick Installation Method.....	5-9

Appendix A SC418 Cables and Hardware

Appendix B SC418 Power Supply Specifications

Appendix C SAS2-216EL1/EL2 Backplane Specifications

C-1	ESD Safety Guidelines.....	C-2
C-2	General Safety Guidelines.....	C-2
C-3	An Important Note to Users.....	C-2
C-4	Introduction to the SAS2-216EL1/EL2 Backplane.....	C-3
C-5	Connectors.....	C-4
C-6	Front Connector and Pin Definitions.....	C-5
C-7	Jumper Locations and Settings.....	C-6
C-8	Front Connectors and LED Indicators.....	C-9
C-9	Single and Dual Port Expanders.....	C-11
C-10	Failover.....	C-12
C-11	Failover with RAID Cards and Multiple HBAs.....	C-13
C-12	Chassis Power Card and Support Cables.....	C-14
C-13	Supported Cascading Configurations.....	C-23

Chapter 1

Introduction

1-1 Overview

Optimized for enterprise-level heavy-capacity storage applications, Supermicro's SC418 chassis supports 4-way serverboards that demand high volume I/O or computational usage and features twenty-four or forty-eight hot-swap 2.5" SAS/SATA hard drive carriers and two fixed internal 3.5" hard drive bays in a 4U chassis. The SC418 design offers maximum HDD per space ratio in a 4U form factor, high power efficiency (up to 94%) with up to (2+1) redundant power supplies, optimized HDD signal trace routing and improved HDD carrier design to dampen HDD vibrations and maximize performance.

1-2 Shipping List

Part Numbers

Please visit the following link for the latest shipping lists and part numbers for your particular chassis model <http://www.supermicro.com/>

SC418 Chassis			
Model	HDD	I/O Slots	Power Supply
SC418E16-R1K62B	24x SAS/ SATA	(7+4) FF	1620W Redundant
SC418E16-R1K62B2	48x SAS/ SATA	(7+4) FF	1620W Redundant

FF: Full-height, full-length.

1-3 Where to get Replacement Components

Though not frequently, you may need replacement parts for your system. To ensure the highest level of professional service and technical support, we strongly recommend purchasing exclusively from our Supermicro Authorized Distributors/System Integrators/Resellers. A list of Supermicro Authorized Distributors/System Integrators/Resellers can be found at: <http://www.supermicro.com>. Click the Where to Buy link.

1-4 Contacting Supermicro

Headquarters

Address: Super Micro Computer, Inc.
980 Rock Ave.
San Jose, CA 95131 U.S.A.

Tel: +1 (408) 503-8000

Fax: +1 (408) 503-8008

Email: marketing@supermicro.com (General Information)
support@supermicro.com (Technical Support)

Web Site: www.supermicro.com

Europe

Address: Super Micro Computer B.V.
Het Sterrenbeeld 28, 5215 ML
's-Hertogenbosch, The Netherlands

Tel: +31 (0) 73-6400390

Fax: +31 (0) 73-6416525

Email: sales@supermicro.nl (General Information)
support@supermicro.nl (Technical Support)
rma@supermicro.nl (Customer Support)

Web Site: www.supermicro.com

Asia-Pacific

Address: Super Micro Computer, Inc.
3F, No. 150, Jian 1st Rd.
Zhonghe Dist., New Taipei City 235
Taiwan (R.O.C)

Tel: +886-(2) 8226-3990

Fax: +886-(2) 8226-3992

Email: support@supermicro.com.tw

Tel: +886-(2)-8226-3990

Web Site: www.supermicro.com.tw

1-5 Returning Merchandise for Service

A receipt or copy of your invoice marked with the date of purchase is required before any warranty service will be rendered. You can obtain service by calling your vendor for a Returned Merchandise Authorization (RMA) number. When returning to the manufacturer, the RMA number should be prominently displayed on the outside of the shipping carton, and mailed prepaid or hand-carried. Shipping and handling charges will be applied for all orders that must be mailed when service is complete.

For faster service, RMA authorizations may be requested online (<http://www.supermicro.com/support/rma/>).

Whenever possible, repack the chassis in the original Supermicro carton, using the original packaging material. If these are no longer available, be sure to pack the chassis securely, using packaging material to surround the chassis so that it does not shift within the carton and become damaged during shipping.

This warranty only covers normal consumer use and does not cover damages incurred in shipping or from failure due to the alteration, misuse, abuse or improper maintenance of products.

During the warranty period, contact your distributor first for any product problems.

Chapter 2

Standardized Warning Statements for AC Systems

2-1 About Standardized Warning Statements

The following statements are industry standard warnings, provided to warn the user of situations which have the potential for bodily injury. Should you have questions or experience difficulty, contact Supermicro's Technical Support department for assistance. Only certified technicians should attempt to install or configure components.

Read this appendix in its entirety before installing or configuring components in the Supermicro chassis.

These warnings may also be found on our web site at http://www.supermicro.com/about/policies/safety_information.cfm.

Warning Definition



Warning!

This warning symbol means danger. You are in a situation that could cause bodily injury. Before you work on any equipment, be aware of the hazards involved with electrical circuitry and be familiar with standard practices for preventing accidents.

警告の定義

この警告サインは危険を意味します。

人身事故につながる可能性がありますので、いずれの機器でも動作させる前に、電気回路に含まれる危険性に注意して、標準的な事故防止策に精通して下さい。

此警告符号代表危險。

您正处于可能受到严重伤害的工作环境中。在您使用设备开始工作之前，必须充分意识到触电的危险，并熟练掌握防止事故发生的标准工作程序。请根据每项警告结尾的声明号码找到此设备的安全性警告说明的翻译文本。

此警告符號代表危險。

您正處於可能身體可能會受損傷的工作環境中。在您使用任何設備之前，請注意觸電的危險，並且要熟悉預防事故發生的標準工作程序。請依照每一注意事項後的號碼找到相關的翻譯說明內容。

Warnung

WICHTIGE SICHERHEITSHINWEISE

Dieses Warnsymbol bedeutet Gefahr. Sie befinden sich in einer Situation, die zu Verletzungen führen kann. Machen Sie sich vor der Arbeit mit Geräten mit den Gefahren elektrischer Schaltungen und den üblichen Verfahren zur Vorbeugung vor Unfällen vertraut. Suchen Sie mit der am Ende jeder Warnung angegebenen Anweisungsnummer nach der jeweiligen Übersetzung in den übersetzten Sicherheitshinweisen, die zusammen mit diesem Gerät ausgeliefert wurden.

BEWAHREN SIE DIESE HINWEISE GUT AUF.

INSTRUCCIONES IMPORTANTES DE SEGURIDAD

Este símbolo de aviso indica peligro. Existe riesgo para su integridad física. Antes de manipular cualquier equipo, considere los riesgos de la corriente eléctrica y familiarícese con los procedimientos estándar de prevención de accidentes. Al final de cada advertencia encontrará el número que le ayudará a encontrar el texto traducido en el apartado de traducciones que acompaña a este dispositivo.

GUARDE ESTAS INSTRUCCIONES.

IMPORTANTES INFORMATIONS DE SÉCURITÉ

Ce symbole d'avertissement indique un danger. Vous vous trouvez dans une situation pouvant entraîner des blessures ou des dommages corporels. Avant de travailler sur un équipement, soyez conscient des dangers liés aux circuits électriques et familiarisez-vous avec les procédures couramment utilisées pour éviter les accidents. Pour prendre connaissance des traductions des avertissements figurant dans les consignes de sécurité traduites qui accompagnent cet appareil, référez-vous au numéro de l'instruction situé à la fin de chaque avertissement.

CONSERVEZ CES INFORMATIONS.

תקנת הצהרות אזהרה

הצהרות הבאות הן אזהרות על פי תקני התעשייה, על מנת להזהיר את המשתמש מפני חבלה פיזית אפשרית. במידה ויש שאלות או היתקלות בבעיה כלשהי, יש ליצור קשר עם מחלקת תמיכה טכנית של סופרמיקרו. טכנאים מוסמכים בלבד רשאים להתקין או להגדיר את הרכיבים.

יש לקרוא את הנספח במלוואו לפני התקנת או הגדרת הרכיבים במארוזי סופרמיקרו.

تحذير! هذا الرمز يعني خطر انك في حالة يمكن أن تتسبب في اصابة جسدية .
قبل أن تعمل على أي معدات، كن على علم بالمخاطر الناجمة عن الدوائر
الكهربائية
وكن على دراية بالممارسات الوقائية لمنع وقوع أي حوادث
استخدم رقم البيان المنصوص في نهاية كل تحذير للعثور ترجمتها

안전을 위한 주의사항

경고!

이 경고 기호는 위험이 있음을 알려 줍니다. 작업자의 신체에 부상을 야기 할 수 있는 상태에 있게 됩니다. 모든 장비에 대한 작업을 수행하기 전에 전기회로와 관련된 위험요소들을 확인하시고 사전에 사고를 방지할 수 있도록 표준 작업절차를 준수해 주시기 바랍니다.

해당 번역문을 찾기 위해 각 경고의 마지막 부분에 제공된 경고문 번호를 참조하십시오

BELANGRIJKE VEILIGHEIDSINSTRUCTIES

Dit waarschuwings symbool betekent gevaar. U verkeert in een situatie die lichamelijk letsel kan veroorzaken. Voordat u aan enige apparatuur gaat werken, dient u zich bewust te zijn van de bij een elektrische installatie betrokken risico's en dient u op de hoogte te zijn van de standaard procedures om ongelukken te voorkomen. Gebruik de nummers aan het eind van elke waarschuwing om deze te herleiden naar de desbetreffende locatie.

BEWAAR DEZE INSTRUCTIES

Installation Instructions



Warning!

Read the installation instructions before connecting the system to the power source.

設置手順書

システムを電源に接続する前に、設置手順書をお読み下さい。

警告

将此系统连接电源前，请先阅读安装说明。

警告

將系統與電源連接前，請先閱讀安裝說明。

Warnung

Vor dem Anschließen des Systems an die Stromquelle die Installationsanweisungen lesen.

¡Advertencia!

Lea las instrucciones de instalación antes de conectar el sistema a la red de alimentación.

Attention

Avant de brancher le système sur la source d'alimentation, consulter les directives d'installation.

יש לקרוא את הוראות התקנה לפני חיבור המערכת למקור מתח.

اقر إرشادات التركيب قبل توصيل النظام إلى مصدر للطاقة

시스템을 전원에 연결하기 전에 설치 안내를 읽어주십시오.

Waarschuwing

Raadpleeg de installatie-instructies voordat u het systeem op de voedingsbron aansluit.

Circuit Breaker



Warning!

This product relies on the building's installation for short-circuit (overcurrent) protection. Ensure that the protective device is rated not greater than: 250 V, 20 A.

サーキット・ブレーカー

この製品は、短絡(過電流)保護装置がある建物での設置を前提としています。

保護装置の定格が250 V、20 Aを超えないことを確認下さい。

警告

此产品的短路(过载电流)保护由建筑物的供电系统提供,确保短路保护设备的额定电流不大于250V,20A。

警告

此产品的短路(過載電流)保護由建築物的供電系統提供,確保短路保護設備的額定電流不大於250V,20A。

Warnung

Dieses Produkt ist darauf angewiesen, dass im Gebäude ein Kurzschluss- bzw. Überstromschutz installiert ist. Stellen Sie sicher, dass der Nennwert der Schutzvorrichtung nicht mehr als: 250 V, 20 A beträgt.

¡Advertencia!

Este equipo utiliza el sistema de protección contra cortocircuitos (o sobrecorrientes) del edificio. Asegúrese de que el dispositivo de protección no sea superior a: 250 V, 20 A.

Attention

Pour ce qui est de la protection contre les courts-circuits (surtension), ce produit dépend de l'installation électrique du local. Vérifiez que le courant nominal du dispositif de protection n'est pas supérieur à :250 V, 20 A.

מוצר זה מסתמך על הגנה המותקנת במבנים למניעת קצר חשמלי. יש לוודא כי המכשיר המגן מפני הקצר החשמלי הוא לא יותר מ-250 V, 20 A

هذا المنتج يعتمد على معدات الحماية من الدوائر القصيرة التي تم تثبيتها في المبنى

تأكد من أن تقييم الجهاز الوقائي ليس أكثر من: 20A, 250V

경고!

이 제품은 전원의 단락(과전류)방지에 대해서 전적으로 건물의 관련 설비에 의존합니다. 보호장치의 정격이 반드시 250V(볼트), 20A(암페어)를 초과하지 않도록 해야 합니다.

Waarschuwing

Dit product is afhankelijk van de kortsluitbeveiliging (overspanning) van uw elektrische installatie. Controleer of het beveiligde apparaat niet groter gedimensioneerd is dan 220V, 20A.

Power Disconnection Warning



Warning!

The system must be disconnected from all sources of power and the power cord removed from the power supply module(s) before accessing the chassis interior to install or remove system components.

電源切斷の警告

システムコンポーネントの取り付けまたは取り外しのために、シャーシ内部にアクセスするには、

システムの電源はすべてのソースから切斷され、電源コードは電源モジュールから取り外す必要があります。

警告

在你打开机箱并安装或移除内部器件前，必须将系统完全断电，并移除电源线。

警告

在您打開機殼安裝或移除內部元件前，必須將系統完全斷電，並移除電源線。

Warnung

Das System muss von allen Quellen der Energie und vom Netzanschlusskabel getrennt sein, das von den Spg.Versorgungsteilmodulen entfernt wird, bevor es auf den Chassisinnenraum zurückgreift, um Systemsbestandteile anzubringen oder zu entfernen.

¡Advertencia!

El sistema debe ser disconnected de todas las fuentes de energía y del cable eléctrico quitado de los módulos de fuente de alimentación antes de tener acceso el interior del chasis para instalar o para quitar componentes de sistema.

Attention

Le système doit être débranché de toutes les sources de puissance ainsi que de son cordon d'alimentation secteur avant d'accéder à l'intérieur du châssis pour installer ou enlever des composants de système.

אזהרה!

יש לנתק את המערכת מכל מקורות החשמל ויש להסיר את כבל החשמלי מהספק לפני גישה לחלק הפנימי של המארז לצורך התקנת או הסרת רכיבים.

يجب فصل النظام من جميع مصادر الطاقة وإزالة سلك الكهرباء من وحدة امداد الطاقة قبل الوصول إلى المناطق الداخلية للهيكल لتثبيت أو إزالة مكونات الجهاز

경고!

시스템에 부품들을 장착하거나 제거하기 위해서는 새시 내부에 접근하기 전에 반드시 전원 공급장치로부터 연결되어있는 모든 전원과 전기코드를 분리해주어야 합니다.

Waarschuwing

Voordat u toegang neemt tot het binnenwerk van de behuizing voor het installeren of verwijderen van systeem onderdelen, dient u alle spanningsbronnen en alle stroomkabels aangesloten op de voeding(en) van de behuizing te verwijderen

Equipment Installation



Warning!

Only trained and qualified personnel should be allowed to install, replace, or service this equipment.

機器の設置

トレーニングを受け認定された人だけがこの装置の設置、交換、またはサービスを許可されています。

警告

只有经过培训且具有资格的人员才能进行此设备的安装、更换和维修。

警告

只有經過受訓且具資格人員才可安裝、更換與維修此設備。

Warnung

Das Installieren, Ersetzen oder Bedienen dieser Ausrüstung sollte nur geschultem, qualifiziertem Personal gestattet werden.

¡Advertencia!

Solamente el personal calificado debe instalar, reemplazar o utilizar este equipo.

Attention

Il est vivement recommandé de confier l'installation, le remplacement et la maintenance de ces équipements à des personnels qualifiés et expérimentés.

אזהרה!

צוות מוסמך בלבד רשאי להתקין, להחליף את הציוד או לתת שירות עבור הציוד.

يجب أن يسمح فقط للموظفين المؤهلين والمدربين لتثبيت واستبدال أو خدمة هذا الجهاز

경고!

훈련을 받고 공인된 기술자만이 이 장비의 설치, 교체 또는 서비스를 수행할 수 있습니다.

Waarschuwing

Deze apparatuur mag alleen worden geïnstalleerd, vervangen of hersteld door geschoold en gekwalificeerd personeel.

Restricted Area



Warning!

This unit is intended for installation in restricted access areas. A restricted access area can be accessed only through the use of a special tool, lock and key, or other means of security. (This warning does not apply to workstations).

アクセス制限区域

このユニットは、アクセス制限区域に設置されることを想定しています。

アクセス制限区域は、特別なツール、鍵と錠前、その他のセキュリティの手段を用いてのみ出入りが可能です。

警告

此部件应安装在限制进出的场所，限制进出的场所指只能通过使用特殊工具、锁和钥匙或其它安全手段进出的场所。

警告

此裝置僅限安裝於進出管制區域，進出管制區域係指僅能以特殊工具、鎖頭及鑰匙或其他安全方式才能進入的區域。

Warnung

Diese Einheit ist zur Installation in Bereichen mit beschränktem Zutritt vorgesehen. Der Zutritt zu derartigen Bereichen ist nur mit einem Spezialwerkzeug, Schloss und Schlüssel oder einer sonstigen Sicherheitsvorkehrung möglich.

¡Advertencia!

Esta unidad ha sido diseñada para instalación en áreas de acceso restringido. Sólo puede obtenerse acceso a una de estas áreas mediante la utilización de una herramienta especial, cerradura con llave u otro medio de seguridad.

Attention

Cet appareil doit être installée dans des zones d'accès réservés. L'accès à une zone d'accès réservé n'est possible qu'en utilisant un outil spécial, un mécanisme de verrouillage et une clé, ou tout autre moyen de sécurité.

אזור עם גישה מוגבלת

אזהרה!

יש להתקין את היחידה באזורים שיש בהם הגבלת גישה. הגישה ניתנת בעזרת כלי אבטחה בלבד (מפתח, מנעול וכד').

تم تخصيص هذه الوحدة لت تركيبها في مناطق محظورة .
يمكن الوصول إلى منطقة محظورة فقط من خلال استخدام أداة خاصة،
قفل ومفتاح أو أي وسيلة أخرى للأمان

경고!

이 장치는 접근이 제한된 구역에 설치하도록 되어있습니다. 특수도구, 잠금 장치 및 키, 또는 기타 보안 수단을 통해서만 접근 제한 구역에 들어갈 수 있습니다.

Waarschuwing

Dit apparaat is bedoeld voor installatie in gebieden met een beperkte toegang. Toegang tot dergelijke gebieden kunnen alleen verkregen worden door gebruik te maken van speciaal gereedschap, slot en sleutel of andere veiligheidsmaatregelen.

Battery Handling



Warning!

There is the danger of explosion if the battery is replaced incorrectly. Replace the battery only with the same or equivalent type recommended by the manufacturer. Dispose of used batteries according to the manufacturer's instructions.

電池の取り扱い

電池交換が正しく行われなかった場合、破裂の危険性があります。交換する電池はメーカーが推奨する型、または同等のものを使用下さい。使用済電池は製造元の指示に従って処分して下さい。

警告

電池更換不當會有爆炸危險。請只使用同類電池或製造商推薦的功能相當的電池更換原有電池。請按製造商的說明處理廢舊電池。

警告

電池更換不當會有爆炸危險。請使用製造商建議之相同或功能相當的電池更換原有電池。請按照製造商的說明指示處理廢棄舊電池。

Warnung

Bei Einsetzen einer falschen Batterie besteht Explosionsgefahr. Ersetzen Sie die Batterie nur durch den gleichen oder vom Hersteller empfohlenen Batterietyp. Entsorgen Sie die benutzten Batterien nach den Anweisungen des Herstellers.

Attention

Danger d'explosion si la pile n'est pas remplacée correctement. Ne la remplacer que par une pile de type semblable ou équivalent, recommandée par le fabricant. Jeter les piles usagées conformément aux instructions du fabricant.

¡Advertencia!

Existe peligro de explosión si la batería se reemplaza de manera incorrecta. Reemplazar la batería exclusivamente con el mismo tipo o el equivalente recomendado por el fabricante. Desechar las baterías gastadas según las instrucciones del fabricante.

אזהרה!

קיימת סכנת פיצוץ של הסוללה במידה והוחלפה בדרך לא תקינה. יש להחליף את הסוללה בסוג התואם מחברת יצרן מומלצת.

סילוק הסוללות המשומשות יש לבצע לפי הוראות היצרן.

هناك خطر من انفجار في حالة استبدال البطارية بطريقة غير صحيحة فعليك استبدال البطارية فقط بنفس النوع أو ما يعادلها كما أوصت به الشركة المصنعة تخلص من البطاريات المستعملة وفقا لتعليمات الشركة الصانعة

경고!

배터리가 올바르게 교체되지 않으면 폭발의 위험이 있습니다. 기존 배터리와 동일하거나 제조사에서 권장하는 동등한 종류의 배터리로만 교체해야 합니다. 제조사의 안내에 따라 사용된 배터리를 처리하여 주십시오.

Waarschuwing

Er is ontploffingsgevaar indien de batterij verkeerd vervangen wordt. Vervang de batterij slechts met hetzelfde of een equivalent type die door de fabrikant aanbevolen wordt. Gebruikte batterijen dienen overeenkomstig fabrieksvoorschriften afgevoerd te worden.

Redundant Power Supplies



Warning!

This unit might have more than one power supply connection. All connections must be removed to de-energize the unit.

冗長電源装置

このユニットは複数の電源装置が接続されている場合があります。
ユニットの電源を切るためには、すべての接続を取り外さなければなりません。

警告

此部件连接的电源可能不止一个，必须将所有电源断开才能停止给该部件供电。

警告

此装置连接的电源可能不只一个，必须切断所有电源才能停止对该装置的供电。

Warnung

Dieses Gerät kann mehr als eine Stromzufuhr haben. Um sicherzustellen, dass der Einheit kein Strom zugeführt wird, müssen alle Verbindungen entfernt werden.

¡Advertencia!

Puede que esta unidad tenga más de una conexión para fuentes de alimentación. Para cortar por completo el suministro de energía, deben desconectarse todas las conexiones.

Attention

Cette unité peut avoir plus d'une connexion d'alimentation. Pour supprimer toute tension et tout courant électrique de l'unité, toutes les connexions d'alimentation doivent être débranchées.

אם קיים יותר מספק אחד

אזהרה!

ליחידה יש יותר מחיבור אחד של ספק. יש להסיר את כל החיבורים על מנת לרוקן את היחידה.

قد يكون لهذا الجهاز عدة اتصالات بوحدات امداد الطاقة.
يجب إزالة كافة الاتصالات لعزل الوحدة عن الكهرباء

경고!

이 장치에는 한 개 이상의 전원 공급 단자가 연결되어 있을 수 있습니다. 이 장치에 전원을 차단하기 위해서는 모든 연결 단자를 제거해야만 합니다.

Waarschuwing

Deze eenheid kan meer dan één stroomtoevoeraansluiting bevatten. Alle aansluitingen dienen verwijderd te worden om het apparaat stroomloos te maken.

Backplane Voltage



Warning!

Hazardous voltage or energy is present on the backplane when the system is operating. Use caution when servicing.

バックプレーンの電圧

システムの稼働中は危険な電圧または電力が、バックプレーン上にかかっています。

修理する際にはご注意ください。

警告

当系統正在进行时，背板上有很危险的电压或能量，进行维修时务必小心。

警告

當系統正在進行時，背板上有危險的電壓或能量，進行維修時務必小心。

Warnung

Wenn das System in Betrieb ist, treten auf der Rückwandplatine gefährliche Spannungen oder Energien auf. Vorsicht bei der Wartung.

¡Advertencia!

Cuando el sistema está en funcionamiento, el voltaje del plano trasero es peligroso. Tenga cuidado cuando lo revise.

Attention

Lorsque le système est en fonctionnement, des tensions électriques circulent sur le fond de panier. Prendre des précautions lors de la maintenance.

מתח בפנל האחורי

אזהרה!
קיימת סכנת מתח בפנל האחורי בזמן תפעול המערכת. יש להיזהר במהלך
העבודה.

هناك خطر من التيار الكهربائي أو الطاقة الموجودة على اللوحة
عندما يكون النظام يعمل كن حذرا عند خدمة هذا الجهاز

경고!

시스템이 동작 중일 때 후면판 (Backplane)에는 위험한 전압이나 에너지가 발생
합니다. 서비스 작업 시 주의하십시오.

Waarschuwing

Een gevaarlijke spanning of energie is aanwezig op de backplane wanneer het
systeem in gebruik is. Voorzichtigheid is geboden tijdens het onderhoud.

Comply with Local and National Electrical Codes



Warning!

Installation of the equipment must comply with local and national electrical codes.

地方および国の電気規格に準拠

機器の取り付けはその地方および国の電気規格に準拠する必要があります。

警告

设备安装必须符合本地与本国电气法规。

警告

設備安裝必須符合本地與本國電氣法規。

Warnung

Die Installation der Geräte muss den Sicherheitsstandards entsprechen.

¡Advertencia!

La instalación del equipo debe cumplir con las normas de electricidad locales y
nacionales.

Attention

L'équipement doit être installé conformément aux normes électriques nationales et locales.

תיאום חוקי החשמל הארצי

אזהרה!

התקנת הציוד חייבת להיות תואמת לחוקי החשמל המקומיים והארציים.

تركيب المعدات الكهربائية يجب أن يمتثل للقوانين المحلية والوطنية المتعلقة بالكهرباء

경고!

현 지역 및 국가의 전기 규정에 따라 장비를 설치해야 합니다.

Waarschuwing

Bij installatie van de apparatuur moet worden voldaan aan de lokale en nationale elektriciteitsvoorschriften.

Product Disposal



Warning!

Ultimate disposal of this product should be handled according to all national laws and regulations.

製品の廃棄

この製品を廃棄処分する場合、国の関係する全ての法律・条例に従い処理する必要があります。

警告

本产品的废弃处理应根据所有国家的法律和规章进行。

警告

本產品的廢棄處理應根據所有國家的法律和規章進行。

Warnung

Die Entsorgung dieses Produkts sollte gemäß allen Bestimmungen und Gesetzen des Landes erfolgen.

¡Advertencia!

Al deshacerse por completo de este producto debe seguir todas las leyes y reglamentos nacionales.

Attention

La mise au rebut ou le recyclage de ce produit sont généralement soumis à des lois et/ou directives de respect de l'environnement. Renseignez-vous auprès de l'organisme compétent.

סילוק המוצר

אזהרה!

סילוק סופי של מוצר זה חייב להיות בהתאם להנחיות וחוקי המדינה.

عند التخلص النهائي من هذا المنتج ينبغي التعامل معه وفقا لجميع القوانين واللوائح الوطنية

경고!

이 제품은 해당 국가의 관련 법규 및 규정에 따라 폐기되어야 합니다.

Waarschuwing

De uiteindelijke verwijdering van dit product dient te geschieden in overeenstemming met alle nationale wetten en reglementen.

Hot Swap Fan Warning



Warning!

The fans might still be turning when you remove the fan assembly from the chassis. Keep fingers, screwdrivers, and other objects away from the openings in the fan assembly's housing.

ファン・ホットスワップの警告

シャーシから冷却ファン装置を取り外した際、ファンがまだ回転している可能性があります。ファンの開口部に、指、ドライバー、およびその他のものを近づけないで下さい。

警告

当您从机架移除风扇装置，风扇可能仍在转动。小心不要将手指、螺丝起子和其他物品太靠近风扇

警告

當您從機架移除風扇裝置，風扇可能仍在轉動。小心不要將手指、螺絲起子和其他物品太靠近風扇。

Warnung

Die Lüfter drehen sich u. U. noch, wenn die Lüfterbaugruppe aus dem Chassis genommen wird. Halten Sie Finger, Schraubendreher und andere Gegenstände von den Öffnungen des Lüftergehäuses entfernt.

¡Advertencia!

Los ventiladores podran dar vuelta cuando usted quite el montaje del ventilador del chasis. Mantenga los dedos, los destornilladores y todos los objetos lejos de las aberturas del ventilador

Attention

Il est possible que les ventilateurs soient toujours en rotation lorsque vous retirez le bloc ventilateur du châssis. Prenez garde à ce que doigts, tournevis et autres objets soient éloignés du logement du bloc ventilateur.

אזהרה!

כאשר מסירים את חלקי המאוורר מהמארז, יתכן והמאווררים עדיין עובדים. יש להרחיק למרחק בטוח את האצבעות וכלי עבודה שונים מהפתחים בתוך המאוורר

من الممكن أن المراوح لا تزال تدور عند إزالة كتلة المروحة من الهيكل يجب إبقاء الأصابع ومفكات البراغي وغيرها من الأشياء بعيدا عن الفتحات في كتلة المروحة.

경고!

새시로부터 팬 조립품을 제거할 때 팬은 여전히 회전하고 있을 수 있습니다. 팬 조립품 외관의 열려있는 부분들로부터 손가락 및 스크류드라이버, 다른 물체들이 가까이 하지 않도록 배치해 주십시오.

Waarschuwing

Het is mogelijk dat de ventilator nog draait tijdens het verwijderen van het ventilatorsamenstel uit het chassis. Houd uw vingers, schroevendraaiers en eventuele andere voorwerpen uit de buurt van de openingen in de ventilatorbehuizing.

Power Cable and AC Adapter



Warning!

When installing the product, use the provided or designated connection cables, power cables and AC adaptors. Using any other cables and adaptors could cause a malfunction or a fire. Electrical Appliance and Material Safety Law prohibits the use of UL or CSA -certified cables (that have UL/CSA shown on the code) for any other electrical devices than products designated by Supermicro only.

電源コードとACアダプター

製品を設置する場合、提供または指定された接続ケーブル、電源コードとACアダプターを使用下さい。他のケーブルやアダプタを使用すると故障や火災の原因になることがあります。電気用品安全法は、ULまたはCSA認定のケーブル(UL/CSEマークがコードに表記)をSupermicroが指定する製品以外に使用することを禁止しています。

警告

安装此产品时,请使用本身提供的或指定的连接线,电源线和电源适配器.使用其它线材或适配器可能会引起故障或火灾.除了Supermicro所指定的产品,电气用品和材料安全法律规定禁止使用未经UL或CSA认证的线材。(线材上会显示UL/CSA符号)。

警告

安装此產品時,請使用本身提供的或指定的連接線,電源線和電源適配器.使用其它線材或適配器可能會引起故障或火災.除了Supermicro所指定的產品,電氣用品和材料安全法律規定禁止使用未經UL或CSA認證的線材。(線材上會顯示UL/CSA符號)。

Warnung

Bei der Installation des Produkts, die zur Verfügung gestellten oder benannt Anschlusskabel, Stromkabel und Netzteile. Verwendung anderer Kabel und Adapter kann zu einer Fehlfunktion oder ein Brand entstehen. Elektrische Geräte und Material Safety Law verbietet die Verwendung von UL-oder CSA-zertifizierte Kabel, UL oder CSA auf der Code für alle anderen elektrischen Geräte als Produkte von Supermicro nur bezeichnet gezeigt haben.

¡Advertencia!

Al instalar el producto, utilice los cables de conexión previstos o designados, los cables y adaptadores de CA. La utilización de otros cables y adaptadores podría ocasionar un mal funcionamiento o un incendio. Aparatos Eléctricos y la Ley de Seguridad del Material prohíbe el uso de UL o CSA cables certificados que tienen UL o CSA se muestra en el código de otros dispositivos eléctricos que los productos designados por Supermicro solamente.

Attention

Lors de l'installation du produit, utilisez les bables de connection fournis ou désigné. L'utilisation d'autres cables et adaptateurs peut provoquer un dysfonctionnement ou un incendie. Appareils électroménagers et de loi sur la sécurité Matériel interdit l'utilisation de UL ou CSA cables certifiés qui ont UL ou CSA indiqué sur le code pour tous les autres appareils électriques que les produits désignés par Supermicro seulement.

חשמליים ומתאמי AC

אזהרה!

כאשר מתקינים את המוצר, יש להשתמש בכבלים, ספקים ומתאמים AC אשר נועדו וסופקו לשם כך. שימוש בכל כבל או מתאם אחר יכול לגרום לתקלה או קצר חשמלי. על פי חוקי שימוש במכשירי חשמל וחוקי בטיחות, קיים איסור להשתמש בכבלים המוסמכים ב- UL או ב- CSA (כשאר מופיע עליהם קוד של UL/CSA) עבור כל מוצר חשמלי אחר שלא צויין על ידי סופרמיקרו בלבד.

عند تركيب الجهاز يجب استخدام كابلات التوصيل، والكابلات الكهربائية ومحولات التيار المتردد التي . أن استخدام أي كابلات ومحولات أخرى يتسبب في حدوث عطل أو حريق. تم توفيرها لك مع المنتج الأجهزة الكهربائية ومواد قانون السلامة يحظر استخدام الكابلات CSA أو UL معتمدة من قبل لأي أجهزة كهربائية أخرى غير المنتجات المعينة من قبل Supermicro (التي تحمل علامة UL/CSA)

경고!

제품을 설치할 때에는 제공되거나 지정된 연결케이블과 전원케이블, AC 어댑터를 사용해야 합니다. 그 밖의 다른 케이블들이나 어댑터들은 고장 또는 화재의 원인이 될 수 있습니다. 전기용품안전법 (Electrical Appliance and Material Safety Law)은 슈퍼마이크로에서 지정한 제품들 외에는 그 밖의 다른 전기 장치들을 위한 UL 또는 CSA에서 인증한 케이블(전선 위에 UL/CSA가 표시)들의 사용을 금지합니다.

Waarschuwing

Bij het installeren van het product, gebruik de meegeleverde of aangewezen kabels, stroomkabels en adapters. Het gebruik van andere kabels en adapters kan leiden tot een storing of een brand. Elektrisch apparaat en veiligheidsinformatiebladen wet verbiedt het gebruik van UL of CSA gecertificeerde kabels die UL of CSA die op de code voor andere elektrische apparaten dan de producten die door Supermicro alleen.

Notes

Chapter 3

System Interface

3-1 Overview

The chassis includes:

- A control panel on the front, left handle of the chassis that houses power buttons and status monitoring lights
- Status lights on externally accessible hard drives
- Status lights for the power supply visible from the back of the chassis

These elements are described in this chapter with possible responses.

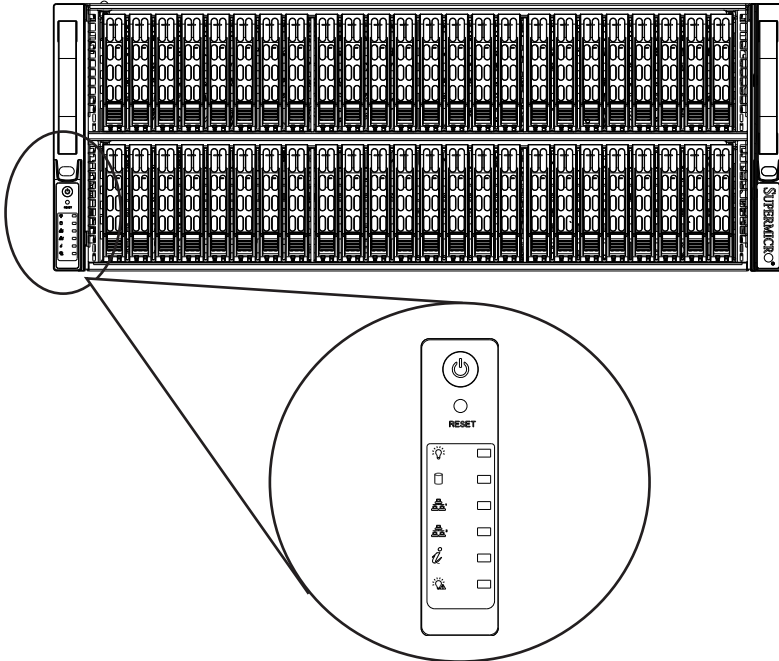

Figure 3-1. Control Panel

3-2 Control Panel Buttons

The chassis includes two push-buttons that control power to the system.



Power: The main power switch is used to apply or remove power from the power supply to the server system. Turning off system power with this button removes the main power but keeps standby power supplied to the system. Therefore, you must unplug system before servicing.

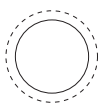

Reset: The reset button is used to reboot the system.

3-3 Control Panel LEDs

There are six LEDs that provide status information about the system.



Power: Indicates power is being supplied to the system power supply units. This LED should normally be illuminated when the system is operating.



HDD: Indicates activity on the hard disk drive or DVD drive when flashing.



NIC1: Indicates network activity on GLAN1 when flashing.



NIC2: Indicates network activity on GLAN2 when flashing.



Information LED: Alerts operator of several states, as noted in the table below.

Informational LED	
Status	Description
Solid red	An overheat condition has occurred. (This may be caused by cable congestion)
Blinking red (1Hz)	Fan failure, check for an inoperative fan.
Blinking red (0.25Hz)	Power failure, check for a non-operational power supply
Solid blue	Local UID has been activated. Use this function to locate the server in a rack mount environment.
Blinking blue (300 msec)	Remote UID is on. Use this function to identify the server from a remote location.



Power Failure: When this LED is continuously on and red, it indicates a failure in the redundant power supply.

Overheating

There are several possible responses if the system overheats.

If the server overheats:

1. Use the LEDs to determine the nature of the overheating condition.
2. Confirm that the chassis covers are installed properly.
3. Check the routing of the cables and make sure all fans are present and operating normally.
4. Verify that the heatsinks are installed properly.

3-4 Drive Carrier LEDs

The chassis includes externally accessible SAS/SATA drives. Each drive carrier displays two status LEDs on the front of the carrier.

- **Green:** When illuminated, this LED indicates drive activity. It blinks on and off when that particular drive is being accessed. This function is controlled by the backplane.
- **Red:** When illuminated, this LED indicates a drive failure. You should be notified by your system management software.

3-5 Power Supply LEDs

On the rear of the power supply module, an LED displays the status.

- **Solid Green:** When illuminated, indicates that the power supply is on.
- **Solid Amber:** When illuminated, indicates the power supply is plugged in and turned off, or the system is off but in an abnormal state.
- **Blinking Amber:** When blinking, this system power supply temperature has reached 63C. The system will automatically power-down when the power supply temperature reaches 70C and restarts when the power supply temperature goes below 60C.

Chapter 4

Chassis Setup and Maintenance

4-1 Overview

This chapter covers the steps required to install components and perform maintenance on the chassis. The only tool required is a Phillips screwdriver.

Review the warnings and precautions listed in the manual before setting up or servicing this chassis. These include information in Chapter 2: System Safety and the warning/precautions listed in the setup instructions

4-2 Removing Power from the System

Before performing most setup or maintenance tasks, use the following procedure to ensure that power has been removed from the system.

1. Use the operating system to power down the node, following the on-screen prompts.
2. After the system has completely shut-down, carefully grasp the head of the power cord and gently pull it out of the back of the power supply. If your system has dual power supplies, remove the cords from both power supplies.
3. Disconnect the cord from the power strip or wall outlet.

4-3 Removing the Chassis Top Cover

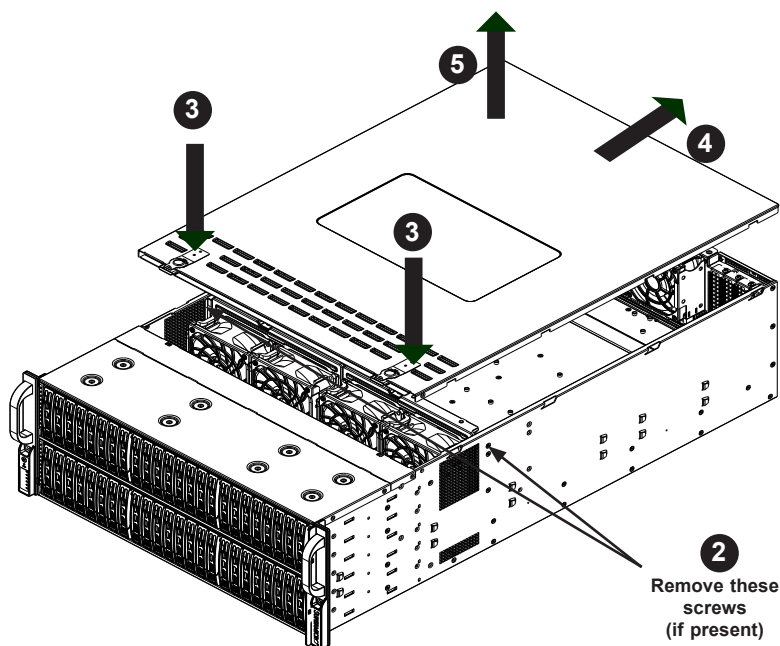

Figure 4-1: Removing the Chassis Top Cover

Removing the Chassis Top Cover

1. Power down the system and unplug the cords from the back of the power supplies.
2. Remove the screws securing the top cover to the chassis if these screws are present.
3. Simultaneously press the release tabs to free the top cover from the locked position.
4. Slide the top cover toward the rear of the chassis.
5. Lift the top cover off the chassis.

Caution: Except for short periods of time, do *not* operate the server without the cover in place. The chassis cover must be in place to allow proper airflow and prevent overheating.

4-4 Installing and Removing Hard Drives

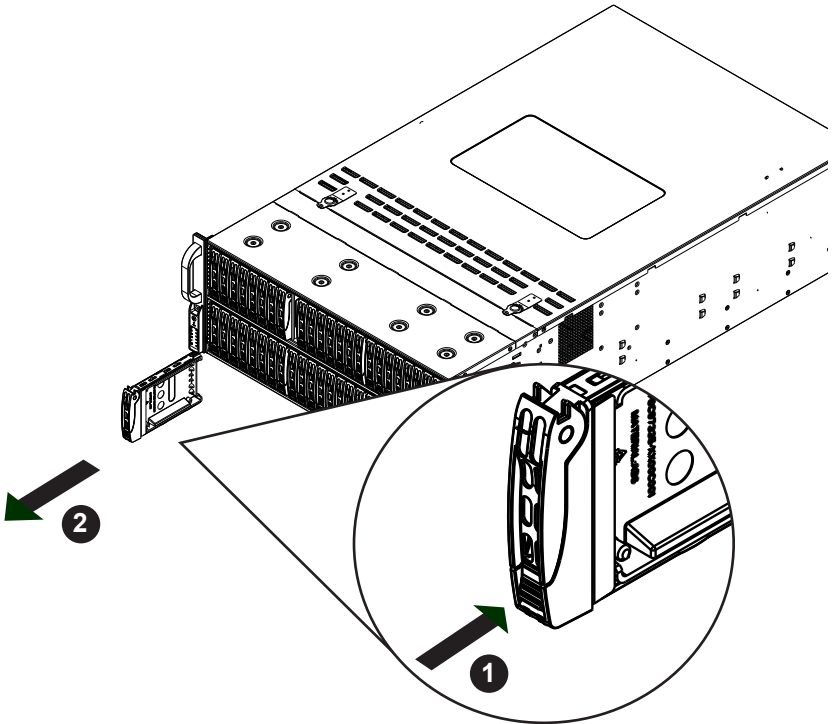

Figure 4-2: Removing the Hard Drive Carrier

The SC418 supports hot-swappable hard drive carriers, which may be removed from the chassis without powering down the system.

Removing Hard Drive Carriers from the Chassis

1. Press the release button on the drive carrier. This extends the drive carrier handle.
2. Use the handle to pull the drive carrier out of the chassis.

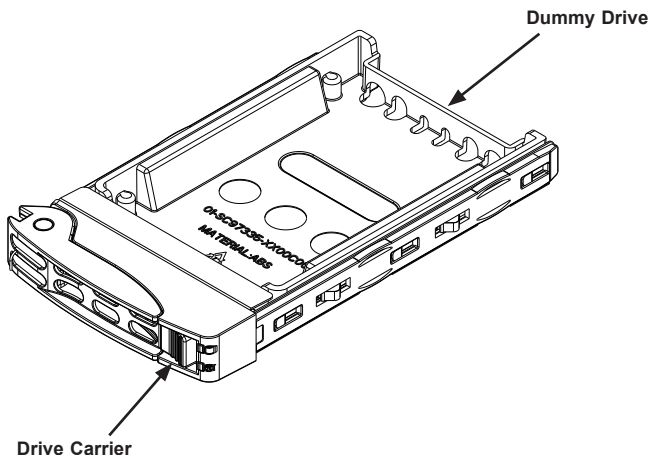

Figure 4-3: Removing Dummy Drive from Carrier

The drives are mounted in drive carriers to simplify their installation and removal from the chassis. These carriers also help promote proper airflow for the drive bays.

Installing a Hard Drive to the Hard Drive Carrier

1. Remove the four screws securing the dummy drive to the drive carrier and remove the dummy drive.

Caution: Except for short periods of time (swapping hard drives), do not operate the server with the hard drive bays empty.

2. Place the hard drive carrier on a flat surface such as a desk, table or work bench.

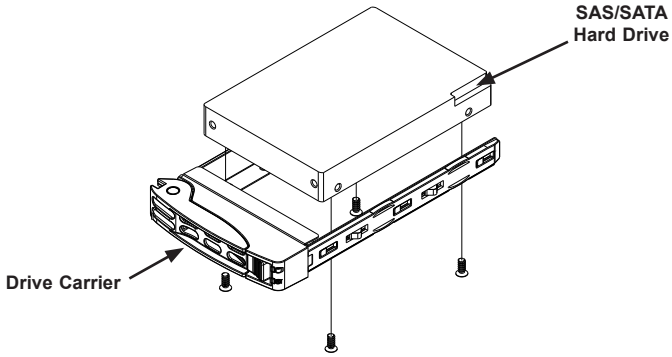

Figure 4-4: Installing the Hard Drive into the Carrier

3. Slide the hard drive into the carrier with the printed circuit board side facing down.
4. Carefully align the mounting holes in both the drive carrier and the hard drive.
5. Secure the hard drive to the carrier using four screws.
6. Install the drive carrier back into the chassis. Make sure to close the drive carrier handle to lock the drive carrier in place.

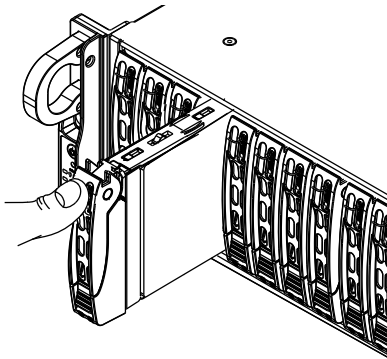

Figure 4-5: Installing the Drive Carrier into the Chassis

4-5 Installing the Motherboard

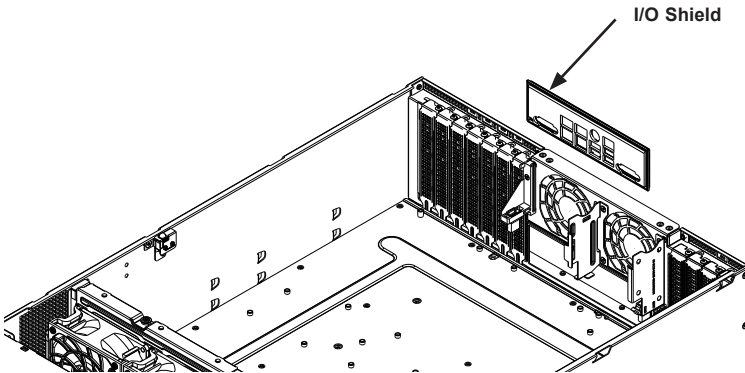

Figure 4-6: I/O Shield Placement

I/O Shield

The I/O shield holds the motherboard ports in place. Install the I/O shield before you install the motherboard.

Installing the I/O Shield

1. Power down the system as described in Section 4-2 and remove the cover.
2. With the illustrations facing the outside of the chassis, place the shield into the space provided.
3. Once installed, the I/O shield will hold the motherboard in place.
4. Replace the chassis cover, plug the power cords into the back of the power supply and power up the system.

Permanent and Optional Standoffs

Standoffs prevent short circuits by securing space between the motherboard and the chassis surface. The SC418 chassis includes permanent standoffs in locations used by most motherboards, and optional standoffs are included in the SC418 accessories packaging.

To use an optional standoff, you must place the standoff through the bottom of the chassis and secure it with the rounded end upward.



M/B standoff
M5 to 6-32

Chassis Standoffs

Some motherboards require additional screws for heatsinks, general components and/or non-standard security. These additional standoffs are included with the motherboard.

Installing the Motherboard

1. Review the documentation that came with your motherboard. Become familiar with component placement, requirements, precautions, and cable connections.
2. Power down the system as described in Section 4-2 and remove the cover.
3. Remove the two screws which secure the middle fan bracket into the chassis as illustrated below and set them aside for later use. (Unplug the fan connectors from the original motherboard if necessary) and lift the middle fan bracket up and out of the chassis.

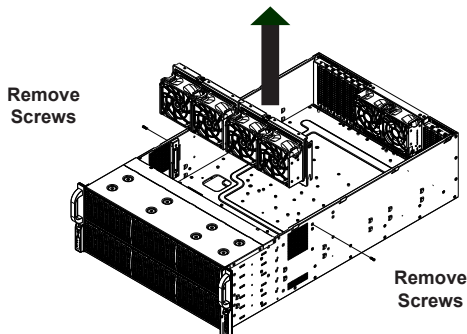

Figure 4-7: Removing the Middle Fan Bracket

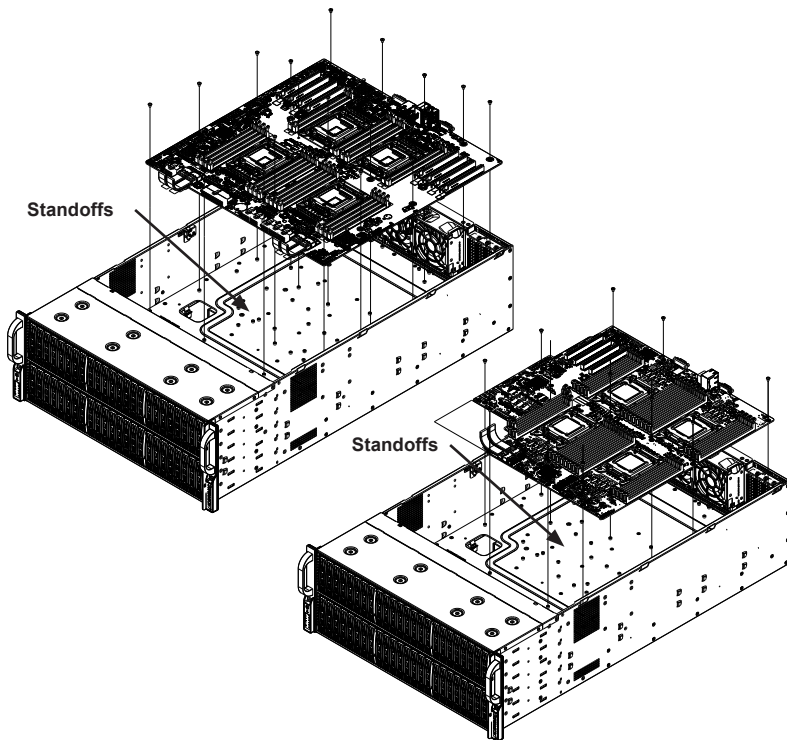

Figure 4-8: Installation of the X9QR7-TF-JBOD and X9QR7-TF+ Motherboards

4. As required by your motherboard, install optional standoffs in any areas that do not have a permanent standoff. To do this, place a hexagonal standoff through the bottom of the chassis and tighten the standoff with a wrench.
5. Lay the motherboard on the chassis aligning the permanent and optional standoffs
6. Secure the motherboard to the chassis using the rounded, Phillips head 6-32 screws from the accessories packaging. **Caution:** Do not exceed eight inch-pounds of torque when tightening the screws.

7. Secure the CPU(s), heatsinks, and other components to the motherboard as described in the motherboard documentation.
8. Connect the cables between the motherboard, backplane, chassis, front panel, and power supply, as needed. See the Routing Cables in the Peripheral Drawer section of this manual for details on routing cabling to the peripheral drawer.
9. If a H8Q or X7Q motherboard is used, it will be necessary to move the guide brackets to the optional fan bracket position shown in the illustration below. Remove the screws securing the guide brackets to the chassis walls and set them aside. Reattach the guide brackets in the optional fan bracket position using the screws previously set aside.
10. Carefully slide the middle fan bracket along the guide brackets on both sides, back into the chassis, routing the motherboard cables through the gateway at the bottom of the middle fan bracket.
11. Connect the fan cables to the motherboard through the gateway, and double check that no cables are jammed before securing the middle fan bracket with the two screws previously set aside.
12. Replace the chassis top cover, plug the power cords into the backs of the power supply modules and power up the system.

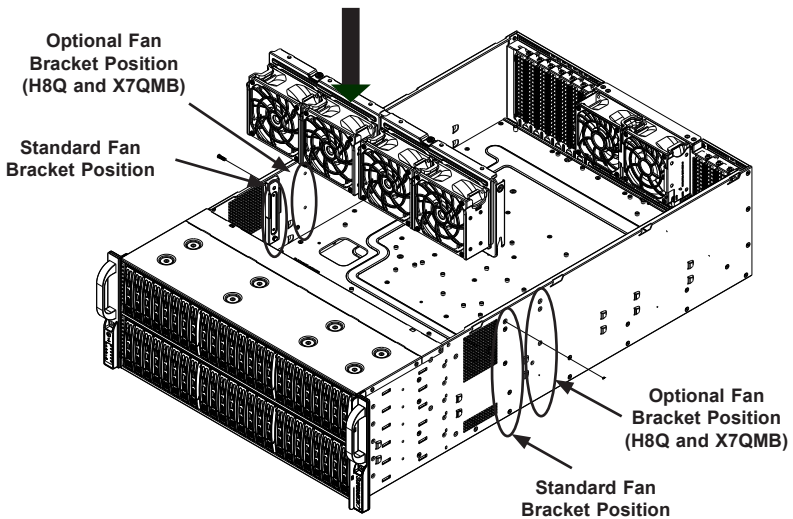

Figure 4-9: Installing the Middle Fan Bracket

Installing Heatsinks on the Motherboard

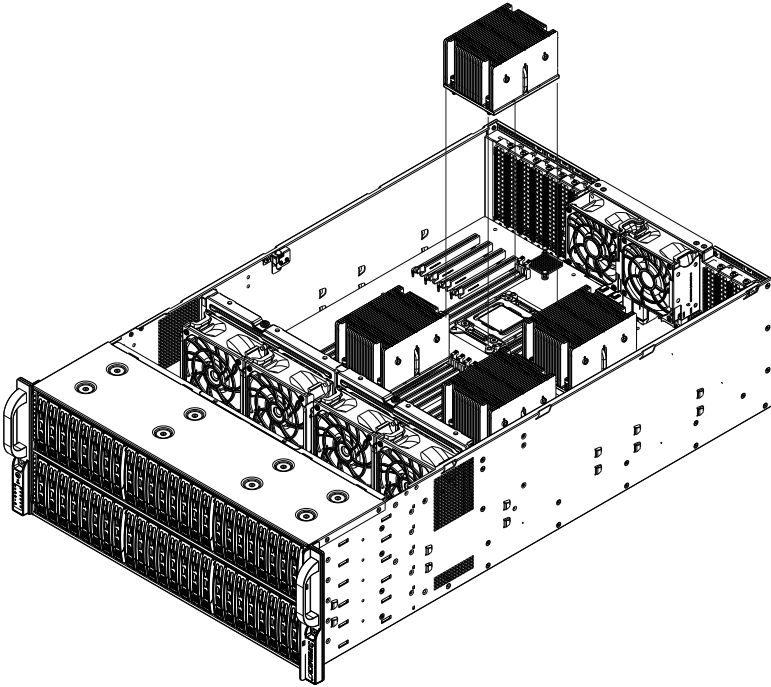

Figure 4-10: Installing Heatsinks on the Motherboard

Heatsinks may be required on the SC418 motherboard. The installation process of these heatsinks may vary with different motherboards. Typically, heatsinks will be secured to the motherboard with screws, and may be installed without removing the motherboard. After powering down the system, removing the power cord from the back of the power supplies and opening the chassis top cover, check the documentation that came with your motherboard for specific instructions on how to install heatsinks.

PCI Slot Setup

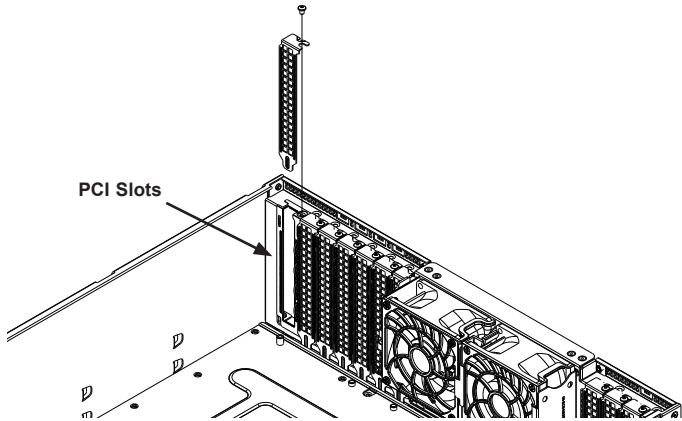

Figure 4-11: Installing Expansion Cards

The SC418 chassis includes eleven PCI slots for expansion cards.

Installing Expansion Cards in the SC418 Chassis

1. Power down the system, remove the cords from the back of the power supplies and open the chassis top cover.
2. Remove the screw holding the cover in place for each expansion card slot you want to use. Keep this screw for later use.
3. Simultaneously insert the expansion card into the PCI slot in the rear of the chassis and into the appropriate slot on the mother board.
4. Secure each card to the chassis using the card's L-bracket and the previously removed screw.
5. Replace the chassis top cover, plug the power cords into the backs of the power supply modules and power up the system.

4-6 Installing the Air Shroud

Air shrouds concentrate airflow to maximize fan efficiency. The SC418 chassis air shroud does not require screws for installation.

Standard air shroud part numbers:

Air Shroud Part No.	Description
MCP-310-84802-0B	Mylar air shroud for AMD H8Q motherboards
MCP-310-84803-0B	Mylar air shroud for the X8Q series and X9QR7-TF+ motherboards
MCP-310-84805-0B	Mylar air shroud for the X9QR7-TF-JBOD motherboard

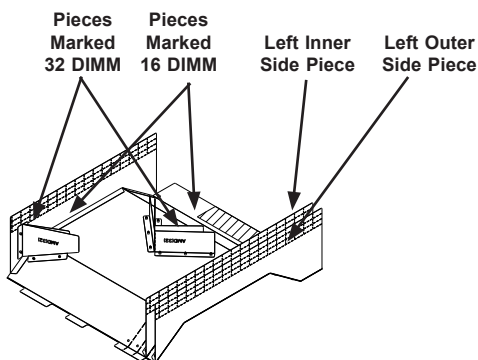

Figure 4-12: Adapting the Air Shroud for AMD Motherboards

Before installing an air shroud with an H8Q motherboard:

16 DIMM: Remove all pieces marked "32 DIMM" and the left outer side piece.

32 DIMM: Remove all pieces marked "16 DIMM" and the left inner side piece.

Before installing an air shroud with an MCP-310-84803-0B Intel motherboard:

X8Q series motherboards: No modifications are required. Keep both posts in place as illustrated below on the left.

X9QR7-TF+ motherboard: Remove the two posts as illustrated below on the right.

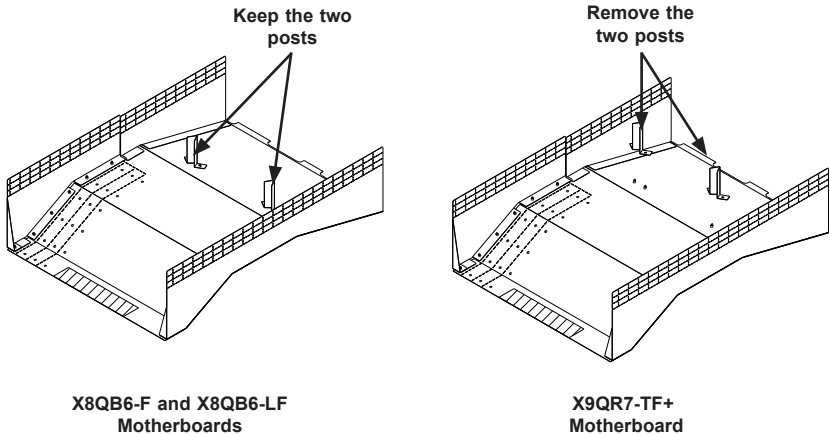
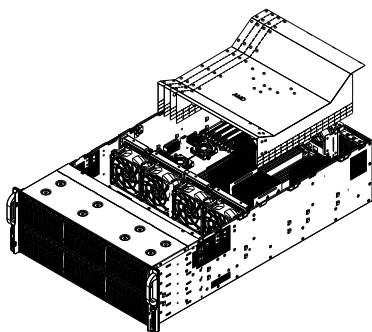

Figure 4-13: Adapting the Air Shroud for Intel Motherboards

Installing the Air Shroud

1. Power down the system, remove the cords from the back of the power supplies and open the chassis top cover.
2. Place air shroud in the chassis, fitting the air shroud between the middle bracket and the rear window.
3. Insert the front hooks of the air shroud into the interstices on the back of the middle fan bracket.
4. Put the top cover back on the chassis, plug the power cords into the back of the power supplies and power up the system.



H8Q Series

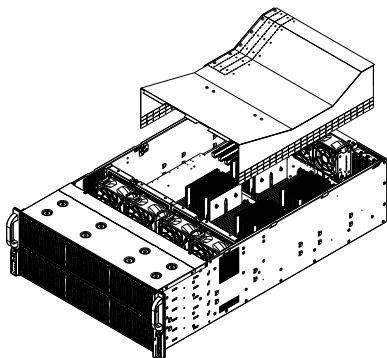

AX9QR7-TF+ X8Q Series

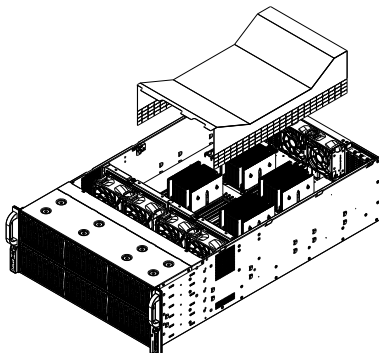

X9QR7-TF-JBOD

Figure 4-14: Air Shrouds for Various Motherboards

Checking the Airflow

Checking the Airflow

- Make sure there are no objects obstructing airflow in and out of the server. In addition, if you are using a front bezel, make sure the bezel's filter is replaced periodically.
- Do not operate the server without drives or drive carriers in the drive bays. Use only recommended server parts.
- Make sure no wires or foreign objects obstruct air flow through the chassis. Pull all excess cabling out of the airflow path or use shorter cables.

The control panel LEDs inform you of system status. See Chapter 3: System Interface for details on the LEDs and the control panel buttons.

Setup Tasks Complete

In most cases, the chassis power supply and fans are pre-installed. If you need to install fans, continue to the System Fans section of this chapter. If the chassis will be installed into a rack, continue to the next chapter for rack installation instructions

4-7 System Fans

Six heavy duty fans provide cooling for the chassis. These fans circulate air through the chassis as a means of lowering the chassis internal temperature.

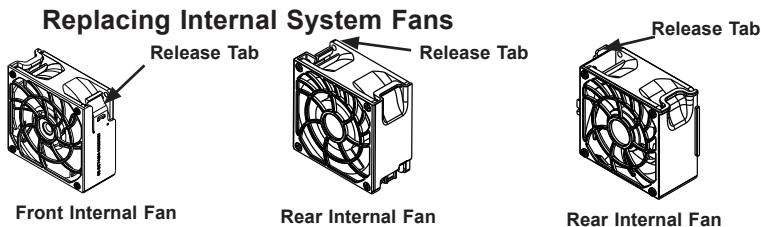

Figure 4-15: Internal System Fans

The SC418 chassis can support six internal system fans.

Replacing an Internal System Fan

1. If necessary, open the chassis top cover while the power is running to determine which fan has failed. (Never run the server for an extended period of time with the chassis top cover open.)
2. Power down the system, unplug the cords from the back of the power supplies and remove the chassis top cover.
3. Press the fan release tab to lift the failed fan from the chassis and pull it completely from the chassis.
4. Place the new fan into the vacant space in the housing while making sure the arrows on the top of the fan (indicating air direction) point in the same direction as the arrows on the other fans.
5. Power up the system and check that the fan is working properly before installing the top cover back onto the chassis.

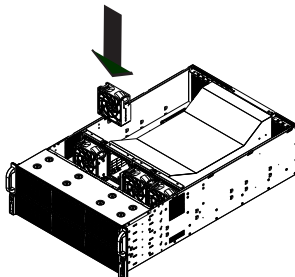

Figure 4-16: Installing a Front System Fan

Installing and Removing External System Fans

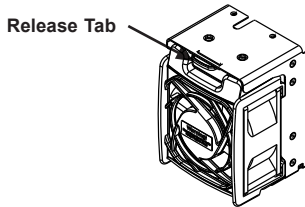

Figure 4-17: External System Fan

The SC418 chassis can support two additional external system fans for those expansion cards without cable outlets. If you are installing an external fan for the first time, follow the instructions below. If you are replacing an existing fan, see the instructions on the following page.

Installing a New External System Fan

1. Power down the system, unplug the cords from the back of the power supplies and remove the chassis cover.
2. If you are installing an external fan for the first time, locate the external fan brackets posts and screws included with the fan package. Secure the posts onto the bracket.



Figure 4-18: External Fan Brackets and Screws

3. Secure the external fan bracket on the rear of the chassis as illustrated using the screws provided.

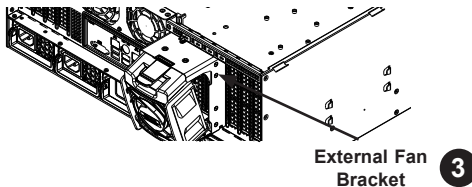

Figure 4-19: Securing the External System Fan Brackets

4. Tie off any excess fan cable inside the fan cage. Insert the holes on the base of the external fan cage onto the posts of the external fan bracket, with the fan cage at a slight angle as shown below, guide the fan cable through the cage outlet.

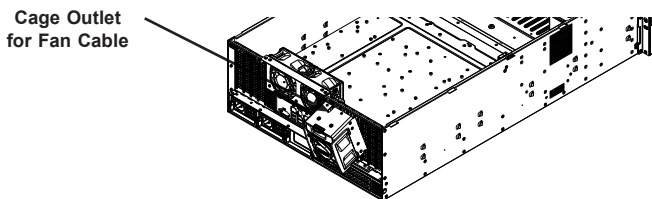

Figure 4-20: External System Fan Cage

5. Bring the external fan cage to an upright position against the rear of the chassis and secure it with two screws as illustrated. Open the breakable cover next to the fan and pass the fan connector through the opening.

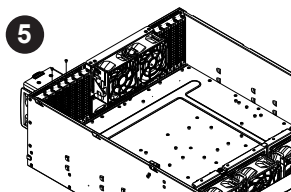

Figure 4-21: Securing the External System Fan Cage

When the SC418 chassis includes a hot-swappable external cooling fan, this fan may be put on or taken off the chassis without powering down the system.

Replacing an Existing External System Fan

1. Press the latch on the top of the fan.
2. Pull the fan away from the rear of the fan cage at a slight angle and lift the posts on the base of the fan out of the holes in the fan cage.

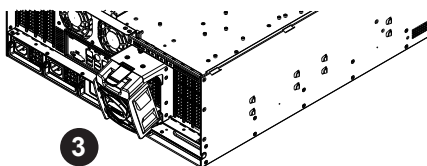

Figure 4-22: Removing the Fan

4-8 Power Supply

The SC418 chassis includes two 1620 Watt (1+1 redundant, up to 2+1 redundant for a total of 3240 Watts) high-efficiency power supplies. These power supplies are auto-switching capable. This enables it to automatically sense and operate at a 100V to 240V input voltage. An amber light will be illuminated on the power supply when the power is off. An illuminated green light indicates that the power supply is operating.

Redundant power supplies are hot-swappable, and can be changed without powering down the system. New units can be ordered directly from Supermicro.

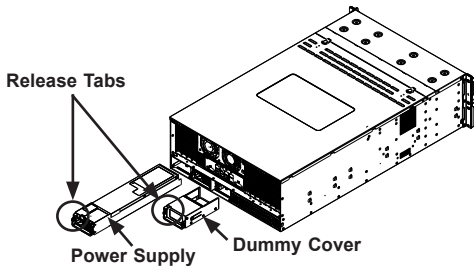

Figure 4-23: Power Supply and Dummy Cover

Replacing the Power Supply

The SC418 chassis includes 1+1 redundant, (up to 2+1 redundant) power supply modules. Any one of the three power supply modules may be removed and new units added without having to power-down the server. The SC418 is shipped with one dummy cover in one of the power bays. Remove this dummy cover prior to use and save it for use when a power supply is removed at a later date.

Removing the Dummy Cover and Adding a Power Supply

1. Press the dummy cover release tab as illustrated above.
2. Pull the dummy cover from the chassis using the handle provided.
3. Insert a new power supply of the same model into the empty power bay.

Replacing a Failed Power Supply

1. Press the release tab on the failed power supply as illustrated above.
2. Replace the failed power module with the same model, or use a dummy cover if power redundancy is not required.
3. Push the new power supply module or dummy cover into the power bay until it clicks into the locked position.

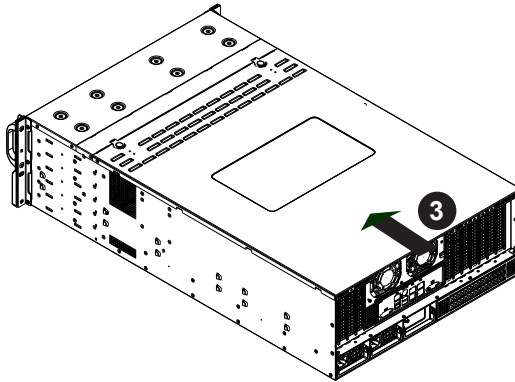

Figure 4-24: Installing the Power Supply

4-9 Changing the Power Distributor Board

The SC418 chassis requires a power distributor. The power distributor provides failover and power supply redundancy. In the unlikely event you must change the power distributor, do following:

Changing the Power Distributor Board

1. Power down the system as described in Section 4-2 and remove the cover.
2. Unplug the fan cables from the motherboard, and then remove the middle fan bracket as described on page 4-7.
3. Remove all power distributor board cables from the motherboard, backplane, and other components and remove all power supplies.
4. Locate the power distributor board bracket underneath the chassis floor, between the power supply and the HDD backplane.
5. Remove the three screws securing the power distributor board bracket to the chassis floor and set them aside for later use.

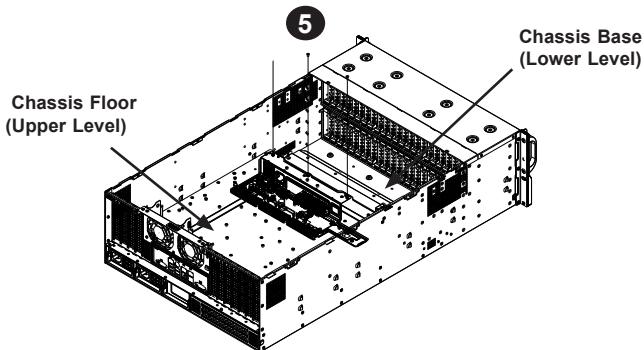

Figure 4-25: Removing Screws Securing the Power Distributor Board Bracket

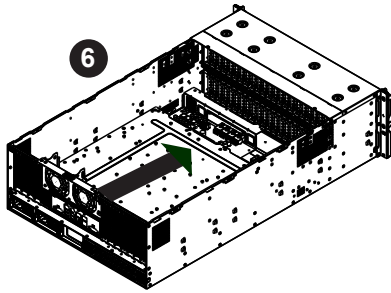

Figure 4-26: Pulling the Power Distributor Board Bracket Forward

6. Pull the power distributor board bracket forward.
7. Rotate the power distributor board bracket out of the chassis.

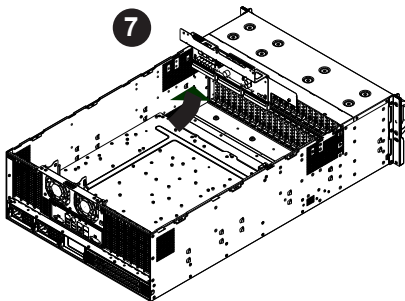

Figure 4-27: Rotating the Power Distributor Board Bracket Out of the Chassis

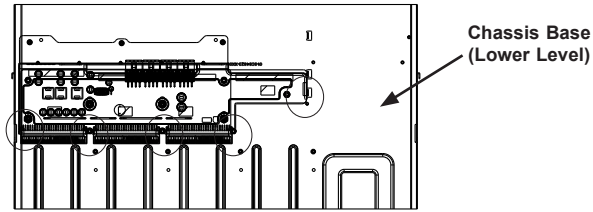
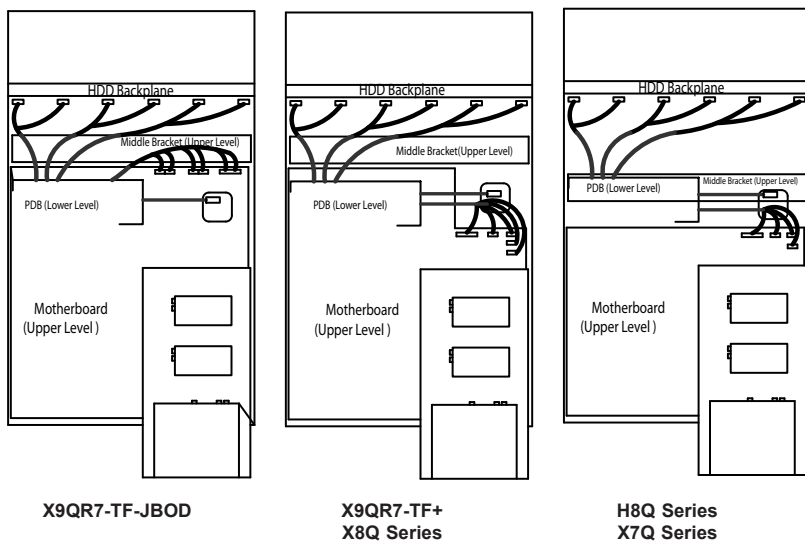

Figure 4-28: Aligning the Power Distributor Board Bracket with the Pins (Pins are Circled in this Illustration)

8. Slide the replacement power distributor board underneath the chassis floor.
9. Gently push the power distributor board bracket **horizontally** until the bottom of the bracket is aligned with the pins in the chassis base.
10. Secure the power distributor board bracket by using the three screws previously set aside as shown in Figure 4-25.
11. Restore the power distributor board connection by plugging three pairs of 4-pin backplane connector cables from the front of the power distributor board bracket as described in figure 4-28. Plug the 24-pin and 8-pin motherboard connector cables to the HDD backplane from the side of the power distributor board bracket to the motherboard at the upper level and leave the 4-pin connector aside for peripheral drawer use.



**Figure 4-29: Routing Cables from the Power Distributor Board
(See Figure 4-28 for details)**

12. Reconnect all the power cables. Spread the power cables to the motherboard evenly before replacing the middle bracket. Make sure the wires passing through the gates of the bracket are not being squeezed.
13. Return the power supplies to their bays in the chassis, replace the top cover, plug the power cords into the back of the power supplies, and power up the system.

4-10 Configuring the Peripheral Drawer

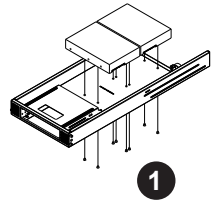

The SC418 chassis supports the following peripheral device configurations, allowing the drawer to be configured for a wide variety of uses:

	Peripheral Device	Optional Bracket Part Number
1.	Single 3.5" HDD	No bracket required
2.	Dual 2.5" HDD	MCP-220-00044-0N
3.	Dummy Cover	MCP-290-11101-0B
4.	Slim USB	MCP-220-00065-0B
5.	Slim 2.5" HDD	MCP-220-00066-0B
6.	Slim FDD	MCP-220-00067-0B
7.	Slim DVD	MCP-220-00068-0N

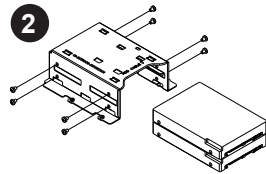

Location	Peripheral Device
Position A	N/A (Default) or 1. or 2.
Position B	N/A (Default) or 1. or 2.
Position C	3. (Default) or 4. or 5. or 6. or 7.
Position D	3. (Default) or 4. or 5. or 6. or 7.

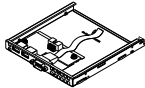
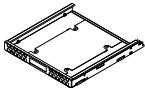

3 Dummy Cover	4 Slim USB	5 Slim 2.5" HDD	6 Slim FDD	7 Slim DVD
				

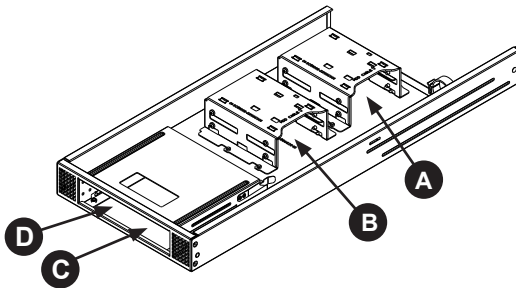

Figure 4-30: Motherboard Node Device Options

Removing the Peripheral Drawer

After selecting the optimal configuration options for your system, follow the instructions below to assemble the peripheral drawer with the options desired.

Opening the Peripheral Drawer

1. Power down the system, unplug the cords from the back of the power supplies and remove the chassis top cover.
2. Unplug the fan cables from the motherboard if necessary, and then remove the middle bracket (See page 4-7)
3. Disconnect the existing power and data cables which extend from the peripheral drawer to other system components (Including the motherboard and the power distributor board).

Caution: Cable lengths in the peripheral drawer only permit the tray to extend half-way open to allow replacement of the peripheral devices. When configuring HDDs, all cables connecting to the drawer must be removed from the motherboard and the power distributor board, before fully extending the drawer and removing it from the chassis

4. Reach beneath the underside of the chassis floor. Pull the peripheral drawer release button while simultaneously using the other fingers to push the back of the peripheral drawer forward and out of the chassis.

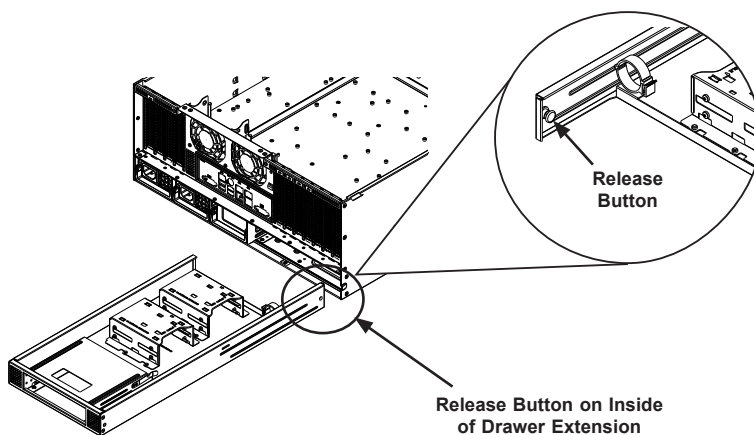

Figure 4-31: Peripheral Device Release Latches

Installing 2.5" and 3.5" Drives in the Peripheral Drawer

The peripheral drawer contains space for hard drives in positions A and B as illustrated below. Each of these positions holds either one 3.5" HDD or two 2.5" HDDs in a mounting bracket for a total of up to two 3.5" HDDs, four 2.5" HDDs or a combination of one 3.5" and two 2.5" HDDs in the peripheral drawer.

Installing HDDs into the Peripheral Drawer

1. Secure the drive into the peripheral drawer using one of the two methods below:

If installing one 3.5" drive, place the drive directly into the peripheral drawer and secure it to the drawer with the four flat head screws provided.

If installing two 2.5" drives, slide the drives into the bracket and secure them into the bracket with eight round head screws as illustrated, then secure the bracket into the drawer, using four flat head screws as illustrated.

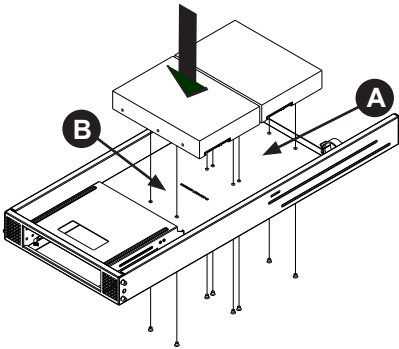

Figure 4-32: Installing 3.5" HDDs into the Peripheral Drawer

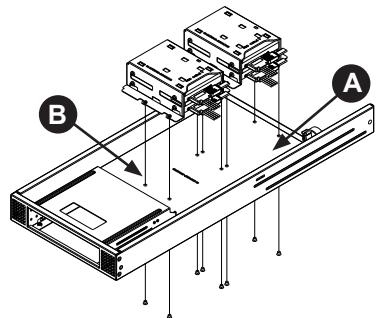

Figure 4-33: Installing 2.5" HDDs into the Peripheral Drawer with Brackets

Installing Peripheral Devices in the Peripheral Drawer

Installing Peripheral Devices

1. Remove the dummy covers from the front of the peripheral device bays on the front of the peripheral drawer.

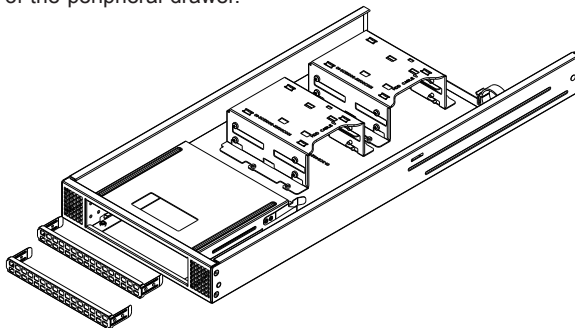

Figure 4-34: Removing the Dummy Covers

2. Install the peripheral devices into the peripheral device bays, pushing them into the bays until they click into the locked position.

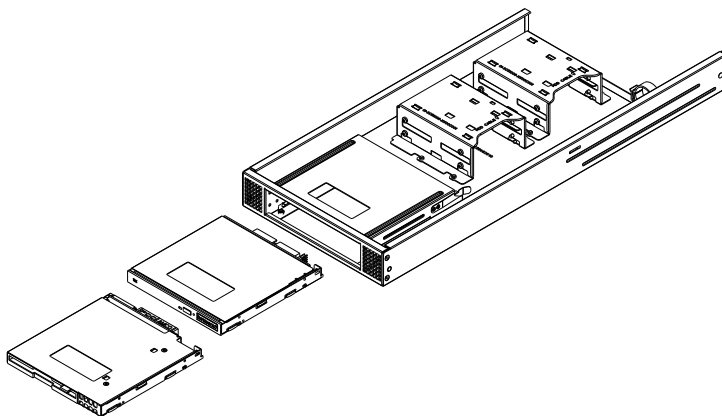

Figure 4-35: Installing Peripheral Devices into the Peripheral Drawer

Removing Peripheral Devices from the Peripheral Drawer

Removing Peripheral Devices

1. Press the release latch on the back of the peripheral device bay towards the wall of the drawer.

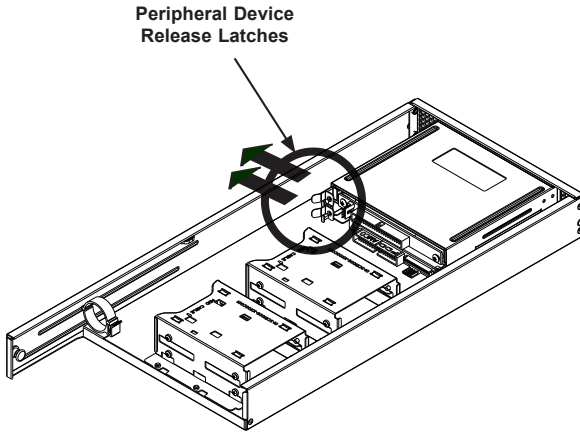

Figure 4-36: Peripheral Device Release Latches

2. Press the back of the peripheral device, gently pushing it forward out the front of the peripheral device bay.

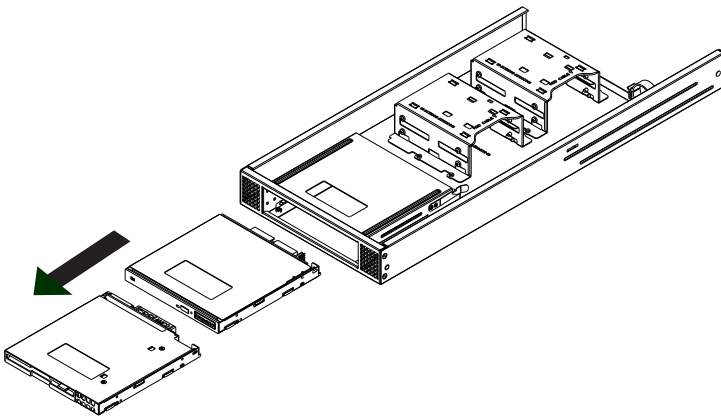

Figure 4-37: Removing Peripheral Devices

Routing Cables in the Peripheral Drawer

Routing Cables in the Peripheral Drawer

1. Connect the power and signal cables to the devices in the peripheral drawer.
2. Route the cables through the O-clip at the back of the drawer.
3. Use zip ties to bundle the cables where indicated in the diagram below.
4. Push the drawer back into the chassis, while simultaneously pulling the cables which lead to the drawer without breaking or disconnecting the cables, until the drawer clicks into the locked position.
5. Connect the power cable to the 4-pin peripheral connector from the power distributor board.
6. Route the signal cable to the upper level and connect them to the motherboard before replacing the middle fan bracket.

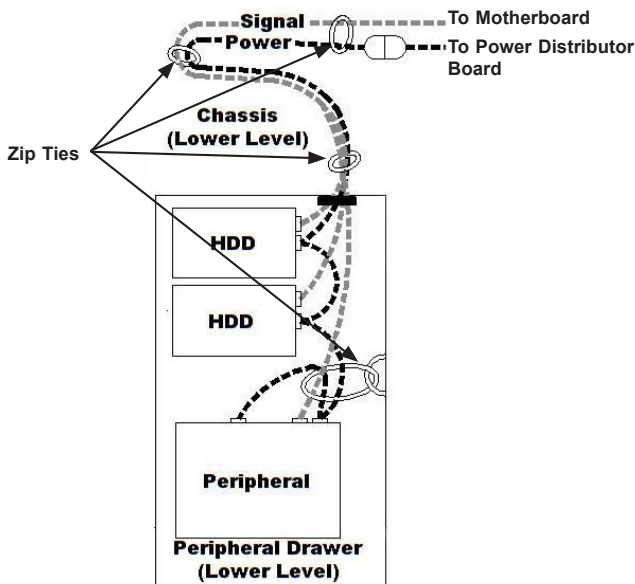

Figure 4-38: Routing Power and Signal Cables

4-11 Accessing the Backplane

The backplane is located behind the hard drives and in front of the middle system fans. In order to change jumper settings on the backplane, it may be necessary to remove the backplane from the chassis.

Removing the Backplane

1. Power down the system, unplug the power cords from the back of the power supply and remove the chassis cover.
2. Pull all of the installed hot-swappable hard drive carriers half-way out of their drive bays in the front of the chassis.
3. Disconnect the cabling to the backplane.
4. Remove the backplane cover, by removing the two screws on the side.

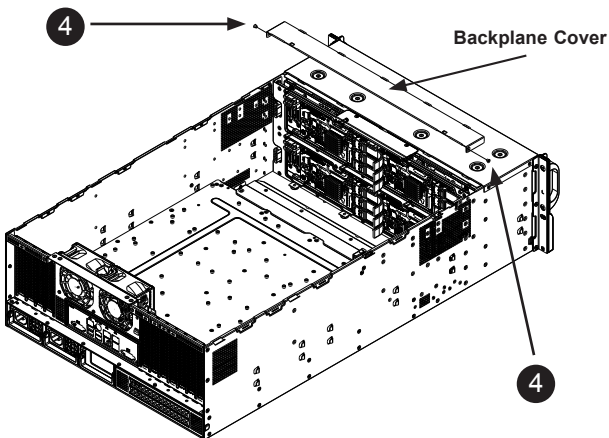

Figure 4-39: Removing the Backplane Cover

5. Remove the ten screws securing backplane housing to the chassis and set these aside for later use.

5a. Remove two upper screws.

5b. Remove four side screws.

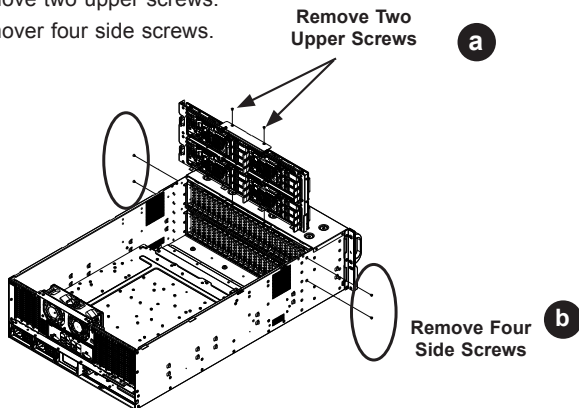

Figure 4-40: Removing the Upper Screws and Side Screws

- 5c. Remove the four lower screws securing the backplane housing to the chassis base.

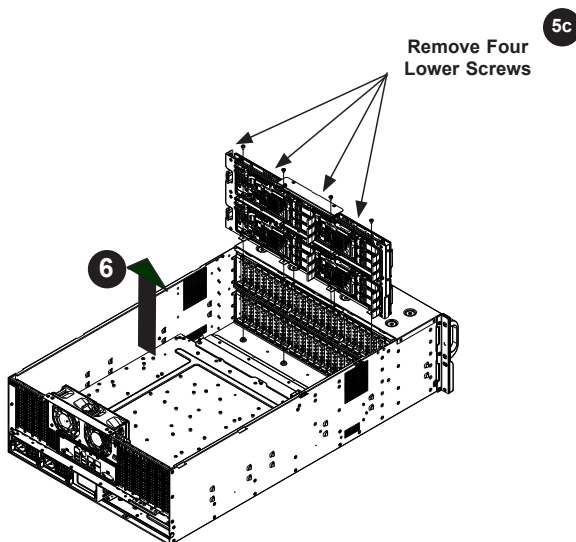

Figure 4-41: Removing the Lower Screws

6. Gently ease the backplane and backplane housing up and out of the chassis

7. Remove the eight screws securing the backplane against the backplane housing. Four screws are located along the top of the backplane housing and four are located along the middle of the backplane housing.
8. Gently remove the backplane from the bracket.

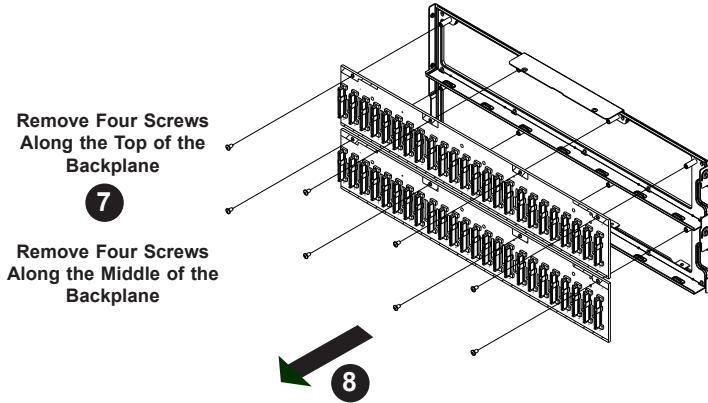

Figure 4-42: Removing the Backplane from the Housing

Installing the Backplane

1. Secure the new backplane into the backplane housing with the eight screws previously set aside. (Figure 4-42)
2. Gently slide the backplane with its housing back into position in the chassis.
3. Replace the four lower screws which secure the backplane housing to the chassis base.
4. Replace the four side screws.

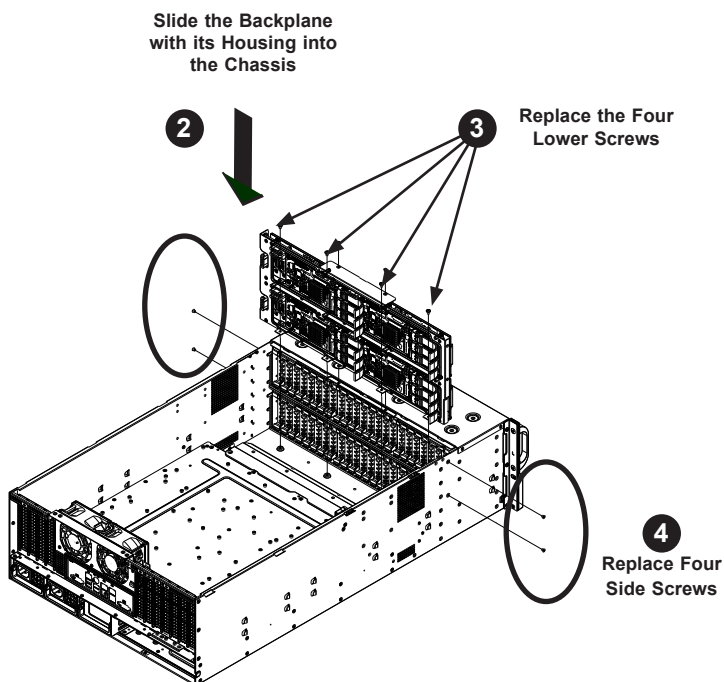

Figure 4-43: Replacing the Backplane and Screws

5. Replace the two upper screws which secure the backplane housing to the chassis.
6. Replace the backplane cover. (Figure 4-39)
7. Reconnect all cables to the backplane.
8. Plug the power cords into the rear of the power supplies, replace the chassis cover and power up the system.

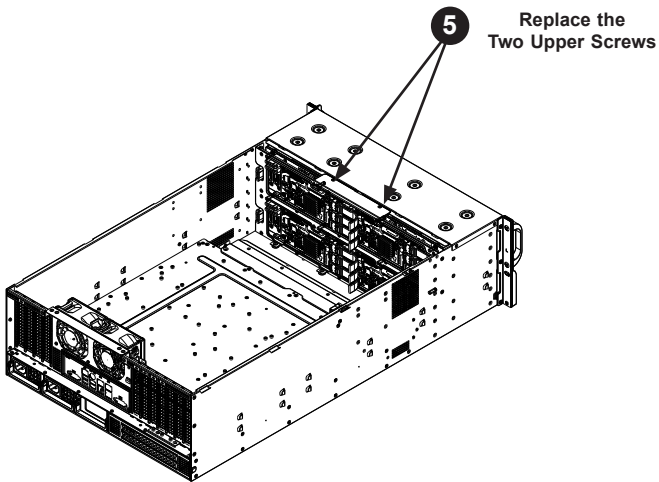

Figure 4-44: Replacing the Upper Screws

Notes

Chapter 5

Rack Installation

This chapter provides instructions for preparing and mounting your chassis in a rack.

5-1 Unpacking the System

You should inspect the box the chassis was shipped in and note if it was damaged in any way. If the chassis itself shows damage, file a damage claim with the carrier who delivered it.

5-2 Preparing for Setup

Decide on a suitable location for the rack unit that will hold your chassis. It should be a clean, dust-free area that is well ventilated. Avoid areas where heat, electrical noise and electromagnetic fields are generated. A nearby grounded power outlet is required.

The box your chassis was shipped in should include two sets of rail assemblies, two rail mounting brackets and the mounting screws to mount the system into the rack. Please read this section in its entirety before beginning the installation procedure.

Choosing a Setup Location

- Leave enough clearance in front of the rack to enable you to open the front door completely (~25 inches).
- Leave approximately 30 inches of clearance in the back of the rack to allow for sufficient airflow and ease in servicing.
- This product is for installation only in a Restricted Access Location (dedicated equipment rooms, service closets and the like).

5-3 Warnings and Precautions

Rack Precautions

- Ensure that the leveling jacks on the bottom of the rack are fully extended to the floor with the full weight of the rack resting on them.
- In single rack installations, stabilizers should be attached to the rack.
- In multiple rack installations, the racks should be coupled together.
- Always make sure that the rack is stable before extending a component from the rack.
- You should extend only one component at a time - extending two or more simultaneously may cause the rack to become unstable.
- When initially installing the server to a rack, test that the rail locking tabs engage to prevent the server from being overextended. Have a rack lift in place as a precaution in case the test fails.
- In any instance of pulling the system from the rack, always use a rack lift and follow all associated safety precautions.

General Server Precautions

- Review the electrical and general safety precautions that came with the components you are adding to your chassis.
- Determine the placement of each component in the rack *before* you install the rails.
- Install the heaviest server components on the bottom of the rack first, and then work upwards.
- Use a regulating uninterruptible power supply (UPS) to protect the server from power surges, voltage spikes and to keep your system operating in case of a power failure.
- Allow the hot plug hard drives and power supply modules to cool before touching them.
- Always keep the rack's front door and all panels and components on the servers closed when not servicing to maintain proper cooling.

5-4 Rack Mounting Considerations

Ambient Operating Temperature

If installed in a closed or multi-unit rack assembly, the ambient operating temperature of the rack environment may be greater than the ambient temperature of the room. Therefore, consideration should be given to installing the equipment in an environment compatible with the manufacturer's maximum rated ambient temperature (TMRA).

Reduced Airflow

Equipment should be mounted into a rack so that the amount of airflow required for safe operation is not compromised.

Mechanical Loading

Equipment should be mounted into a rack so that a hazardous condition does not arise due to uneven mechanical loading.

Circuit Overloading

Consideration should be given to the connection of the equipment to the power supply circuitry and the effect that any possible overloading of circuits might have on overcurrent protection and power supply wiring. Appropriate consideration of equipment nameplate ratings should be used when addressing this concern.

Reliable Ground

A reliable ground must be maintained at all times. To ensure this, the rack itself should be grounded. Particular attention should be given to power supply connections other than the direct connections to the branch circuit (i.e. the use of power strips, etc.).



To prevent bodily injury when mounting or servicing this unit in a rack, you must take special precautions to ensure that the system remains stable. The following guidelines are provided to ensure your safety:

- This unit should be mounted at the bottom of the rack if it is the only unit in the rack.
- When mounting this unit in a partially filled rack, load the rack from the bottom to the top with the heaviest component at the bottom of the rack.
- If the rack is provided with stabilizing devices, install the stabilizers before mounting or servicing the unit in the rack.

5-5 Rack Mounting Instructions

This section provides information on installing the chassis into a rack unit with the rails provided. There are a variety of rack units on the market, which may mean that the assembly procedure will differ slightly from the instructions provided. You should also refer to the installation instructions that came with the rack unit you are using. NOTE: This rail will fit a rack between 26.5" and 36.4" deep.

Identifying the Sections of the Rack Rails

The chassis package includes two rail assemblies in the rack mounting kit. Each assembly consists of three sections: An inner chassis rail which secures directly to the chassis, an outer rail that secures to the rack, and a middle rail which extends from the outer rail. These assemblies are specifically designed for the left and right side of the chassis.

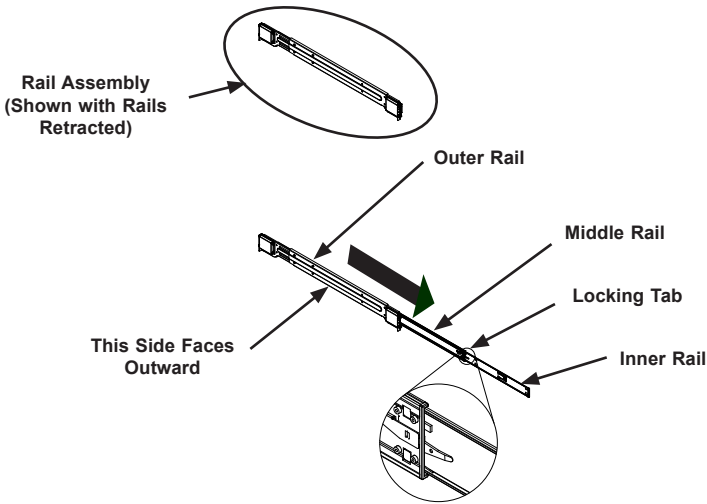

Figure 5-1: Identifying the Outer Rail, Middle Rail and Inner Rails (Left Rail Assembly Shown)

Locking Tabs

Each inner rail has a locking tab. This tab locks the chassis into place when installed and pushed fully into the rack. These tabs also lock the chassis in place when fully extended from the rack. This prevents the server from coming completely out of the rack when the chassis is pulled out for servicing.

Releasing the Inner Rail

Releasing Inner Rail from the Outer Rails

1. Identify the left and right outer rail assemblies as described on page 5-4.
2. Pull the inner rail out of the outer rail until it is fully extended as illustrated below.
3. Press the locking tab down to release the inner rail.
4. Pull the inner rail all the way out.
5. Repeat for the second outer rail.

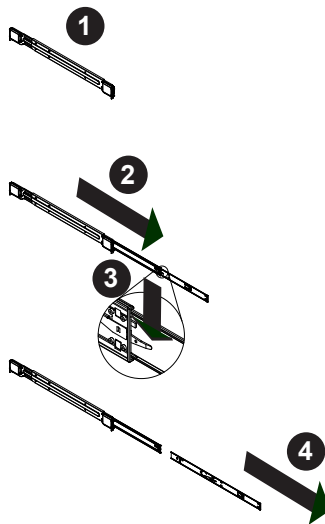

Figure 5-2: Extending and Releasing the Inner Rail

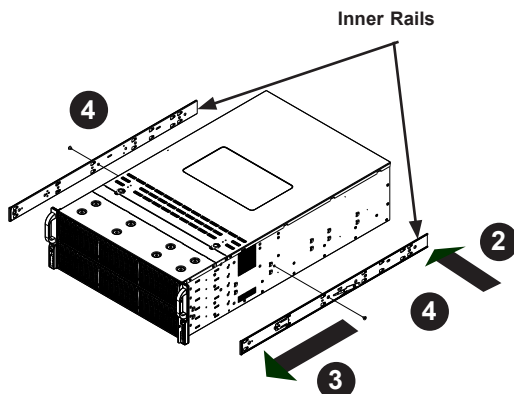

Figure 5-3: Installing the Inner Rails

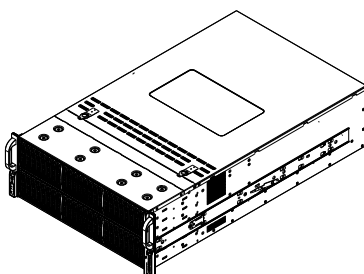

Figure 5-4: Inner Rails Installed on the Chassis

Installing The Inner Rails on the Chassis

Installing the Inner Rails

1. Confirm that the left and right inner rails have been correctly identified.
2. Place the inner rail firmly against the side of the chassis, aligning the hooks on the side of the chassis with the holes in the inner rail.
3. Slide the inner rail forward toward the front of the chassis until the rail clicks into the locked position, which secures the inner rail to the chassis.
4. Secure the inner rail to the chassis with the screws provided.
5. Repeat steps 1 through 4 above for the other inner rail.



Warning: Do not pick up the server by the front handles. They are designed to pull the system from a rack only.

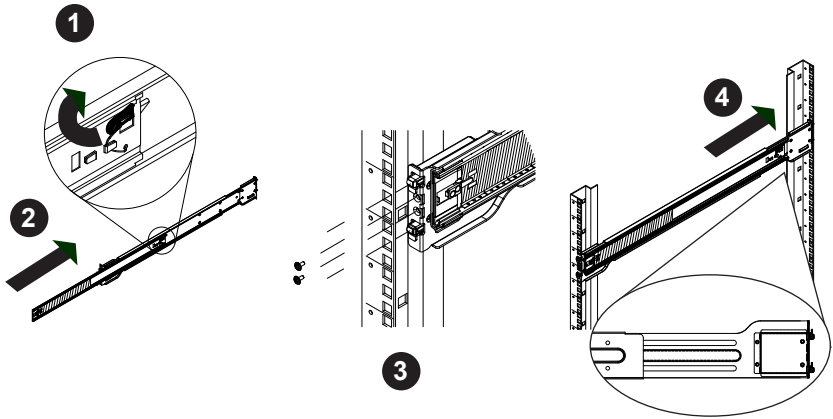

Figure 5-5: Extending and Releasing the Outer Rails

Installing the Outer Rails on the Rack

Installing the Outer Rails

1. Press upward on the locking tab at the rear end of the middle rail.
2. Push the middle rail back into the outer rail.
3. Hang the hooks of the front of the outer rail onto the slots on the front of the rack. If necessary, use screws to secure the outer rails to the rack, as illustrated above.
4. Pull out the rear of the outer rail, adjusting the length until it fits within the posts of the rack.
5. Hang the hooks of the rear portion of the outer rail onto the slots on the rear of the rack. If necessary, use screws to secure the rear of the outer rail to the rear of the rack.
6. Repeat steps 1-5 for the remaining outer rail.

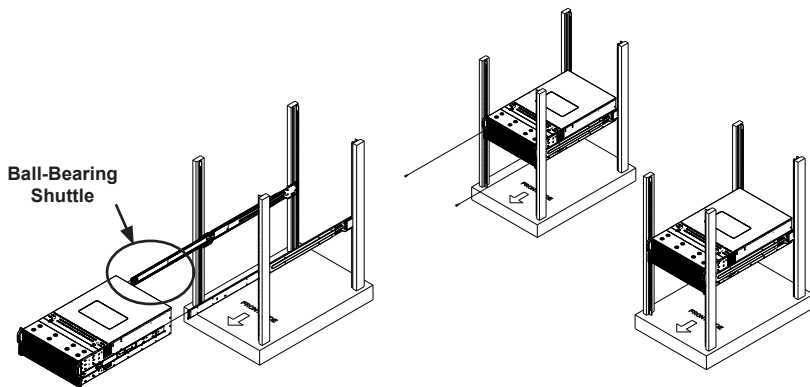

Figure 5-6: Installing into a Rack

Note: Figures are for illustrative purposes only. Always install servers into racks from the bottom up.

Standard Chassis Installation

Installing the Chassis into a Rack

1. Confirm that the inner rails are properly installed on the chassis.
2. Confirm that the outer rails are correctly installed on the rack.
3. Pull the middle rail out from the front of the outer rail and make sure that the ball-bearing shuttle is at the front locking position of the middle rail.
4. Align the chassis inner rails with the front of the middle rails.
5. Slide the inner rails on the chassis into the middle rails, keeping the pressure even on both sides, until the locking tab of the inner rail clicks into the front of the middle rail, locking the chassis into the fully extended position.
6. Depress the locking tabs of both sides at the same time and push the chassis all the way into the rear of the rack.
7. If necessary for security purposes, use screws to secure the chassis handles to the front of the rack.



Stability hazard. The rack stabilizing mechanism must be in place, or the rack must be bolted to the floor before you slide the unit out for servicing. Failure to stabilize the rack can cause the rack to tip over.

Optional Quick Installation Method

The following quick installation method may be used to install the chassis onto a rack.

Installing the Chassis into a Rack

1. Install the whole rail assembly onto the rack as described on page X-7.
2. Release the inner rail without retracting the middle rail.
3. Install the inner rails on the chassis as previously described on page X-6.
4. Install the chassis onto the middle rail as described in the previous section.

Notes

Appendix A

SC418 Cables and Hardware

A-1 Overview

This appendix lists supported cables for your chassis system. It only includes the most commonly used components and configurations. For more compatible cables, refer to the manufacturer of the motherboard you are using and our Web site at: www.supermicro.com.

A-2 Cables Included with SC418 Chassis (SAS/SATA)

SC418E16-R1K62B, SC418E26-R1K62B			
Part #	Type	Length	Description
CBL-0174L	Cable	6'	US power cord, 14 AWG
CBL-0071L	Ribbon, Round	30"	Round 16-pin to 16-pin ribbon FP cable 28AWG
CBL-0088L	Cable	10.5"	4-pin middle fan power extension (PWM)
CBL-0216L	Cable	7.87"-	4 to 4-pin middle fan power extension (PWM)
CBL-0099	Cable	---	Power extension cable, one HDD to two HDD and two FDD
CBL-0233I	Cable	---	Y-cable for 4-pin HDD
CBL-0217L	Cable	---	16-pin control panel converter cable
CBL-0234L	Cable		Y-cable for 4-pin HDD

Extending Power Cables

Although Supermicro chassis are designed with to be efficient and cost-effective, some compatible motherboards have power connectors located in different areas.

To use these motherboards you may have to extend the power cables to the mother boards. To do this, use the following chart as a guide.

Power Cable Extenders		
Number of Pins	Cable Part #	Length
24-pin	CBL-0042	7.9" (20 cm)
20-pin	CBL-0059	7.9" (20 cm)
8-pin	CBL-0062	7.9" (20 cm)
4-pin	CBL-0060	7.9" (20 cm)

Front Panel to the Motherboard

The SC836 chassis includes a cable to connect the chassis front panel to the motherboard. If your motherboard uses a different connector, use the following list to find a compatible cable.

Front Panel to Motherboard Cable (Ribbon Cable)		
Number of Pins (Front Panel)	Number of Pins (Motherboard)	Cable Part #
16-pin	16-pin	CBL- 049
16-pin	20-pin	CBL-0048
20-pin	20-pin	CBL-0047
16-pin	varies	CBL-0068
20-pin	various*	CBL-0067

* Split cables: Use these cable if your motherboard requires several different connections from the front panel.

A-4 Chassis Screws

The accessory box includes all the screws needed to setup your chassis. This section lists and describes the most common screws used. Your chassis may not require all the parts listed.

M/B



Pan head
6-32 x 5 mm
[0.197]

HARD DRIVE



Flat head
6-32 x 5 mm
[0.197]

DVD-ROM, CD-ROM, and FLOPPY DRIVE



Pan head
6-32 x 5 mm
[0.197]



Flat head
6-32 x 5 mm
[0.197]



Round head
M3 x 5 mm
[0.197]



Round head
M2.6 x 5 mm
[0.197]

RAIL



Flat head
M4 x 4 mm
[0.157]



Round head
M4 x 4 mm
[0.157]



Flat head
M5 x 12 mm [0.472]
Washer for M5



M/B STANDOFFS



M/B standoff
6-32 to 6-32



M/B (CPU)
standoff
M5 to 6-32



M/B standoff
M5 to 6-32



Thumb screw
6-32 x 5 mm
[0.197]



1U M/B standoff
6-32 x 5 mm
[0.197]

Notes

Appendix B

SC418 Power Supply Specifications

This appendix lists power supply specifications for your chassis system.

SC418A-R1K62B, SC418E16-R1K62B, SC418E26-R1K62B	
1620W (up to 2+1) for a total of 4860W	
MFR Part #	PWS-1K62P-1R
AC Input	1000W Output @ 100-120V, 12-10A, 50-60Hz 1200W Output @ 120-140V, 12-10A, 50-60Hz 1620W Output @ 180-240V, 10.5-8A, 50-60Hz
DC Output	1000W: +12V/84 Amps; +5Vsb/4 Amps 1200W: +12V/100 Amps; +5Vsb/4 Amps 1620W: +12V/150 Amps; +5Vsb/4 Amps

For ordering purposes, the part number of the power supply dummy cover is CSE-PT0130L.

Notes

Appendix C

SAS2-216EL1/EL2 Backplane Specifications

Overview of the SAS2-216EL1/EL2 Backplanes

The SAS2-216EL1/EL2 model backplanes consists of a SAS2-216EB backplane (A) with one or two SAS2-216EL daughter cards (B and C) mounted on the rear of the backplane.

The SAS2-216EL1 model consists of the SAS2-216EB backplane (A) and **one** SAS2-216EL daughter card (B), mounted on the right-hand side of the backplane.

The SAS2-216EL2 model consists of the SAS2-216EB backplane (A), and **two** SAS-216EL daughter cards (B and C), mounted on the rear of the backplane.

Components on the front side of the SAS2-216EB backplane include twenty-four SAS connectors and their respective activity and failure LEDs. Components on the rear side of the backplane include jumpers and power and fan connectors. The daughter card's components include SAS ports, flash and expander chips, and mode select jumpers.

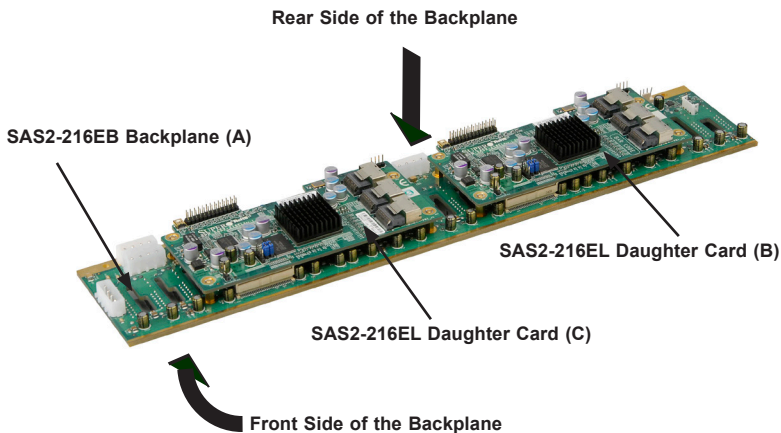

C-1 ESD Safety Guidelines

Electrostatic Discharge (ESD) can damage electronic components. To prevent damage to your system, it is important to handle the backplane very carefully. The following measures are generally sufficient to protect your equipment from ESD.

- Use a grounded wrist strap designed to prevent static discharge.
- Touch a grounded metal object before removing a component from the antistatic bag.
- Handle the backplane and daughter cards by their edges only; do not touch the components, peripheral chips, memory modules or gold contacts.
- When handling chips or modules, avoid touching their pins.
- Put the backplane and peripherals back into their antistatic bags when not in use.

C-2 General Safety Guidelines

To avoid personal injury and property damage, carefully follow all the safety steps listed below when accessing your system or handling the components.

- Always disconnect power cables before installing or removing any components from the computer, including the backplane.
- Disconnect the power cable before installing or removing any cables from the backplane.
- Make sure that the backplane is securely and properly installed on the motherboard to prevent damage to the system due to power shortage.

C-3 An Important Note to Users

All images and layouts shown in this user's guide are based upon the latest PCB Revision available at the time of publishing. The card you have received may or may not look exactly the same as the graphics shown in this manual.

C-4 Introduction to the SAS2-216EL1/EL2 Backplane

The SAS2-216EL1/EL2 model backplane has been designed to utilize the most up-to-date technology available, providing your system with reliable, high-quality performance.

This manual reflects the SAS2-216EL Revision 1.02 backplane, the most current release available at the time of publication.

This manual also describes the SAS2-216EL daughter card, Revision 1.02, the most current release available at the time of publication. Always refer to the Supermicro Web site at www.supermicro.com for the latest updates, compatible parts and supported configurations.

C-5 Connectors

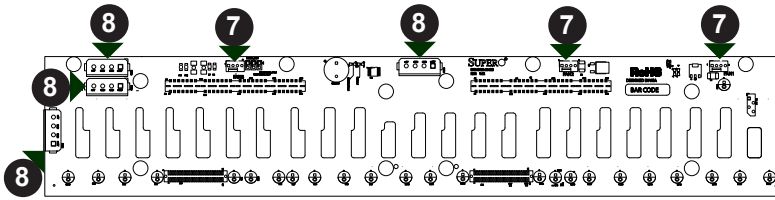

Rear of SAS2-261EB Backplane

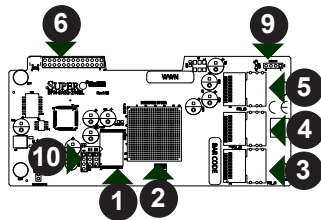

Front of SAS2-216EL Daughter Card(s)

Figure C-1: Connectors on the Backplane and Daughter Cards

Connectors

- | | |
|---------------------|---|
| 1. Flash Chip | 6. EPP Connectors: J2 |
| 2. Expander Chip | 7. Fan Connectors: Fan1, Fan2, and Fan3 |
| 3. SAS Port: PRI_J1 | 8. Power Connectors: PWR1 - PWR4 |
| 4. SAS Port: PRI_J2 | 9. Debug Connector: EXPDBG1 |
| 5. SAS Port: PRI_J3 | 10. UART Connector: SMART_UART |

C-6 Front Connector and Pin Definitions

1. Flash Chips

The flash chip enhances the backplane memory.

2. Expander Chips

This expander chip allows the backplane to support dual ports, cascading, and failover.

3. - 5. SAS Ports

The primary and secondary sets of SAS ports provide expander features including cascading and failover. From right to left the ports are Primary 1,2,3 and Secondary 1,2,3.

6. EPP Ports

The EPP ports are used for manufacturer diagnostic purposes only.

7. Fan Connectors

The 3-pin connectors, designated FAN1, FAN2, and FAN3, provide power to the fans. See the table on the right for pin definitions.

Fan Connectors	
Pin#	Definition
1	Ground
2	+12V
3	Tachometer

8. Backplane Main Power Connectors

The 4-pin connectors are designated PWR1, PWR2, PWR3 and PWR4. They provide power to the backplane. See the table on the right for pin definitions.

Backplane Main Power 4-Pin Connector	
Pin#	Definition
1	+12V
2 and 3	Ground
4	+5V

9. Debug Connector

The debug connector is designated EX-PDBG1 and is used for manufacturer's diagnostic purposes only.

10. UART Connector

The UART connector is designated SMART_UART and is used for manufacturer's diagnostic purposes only.

C-7 Jumper Locations and Settings

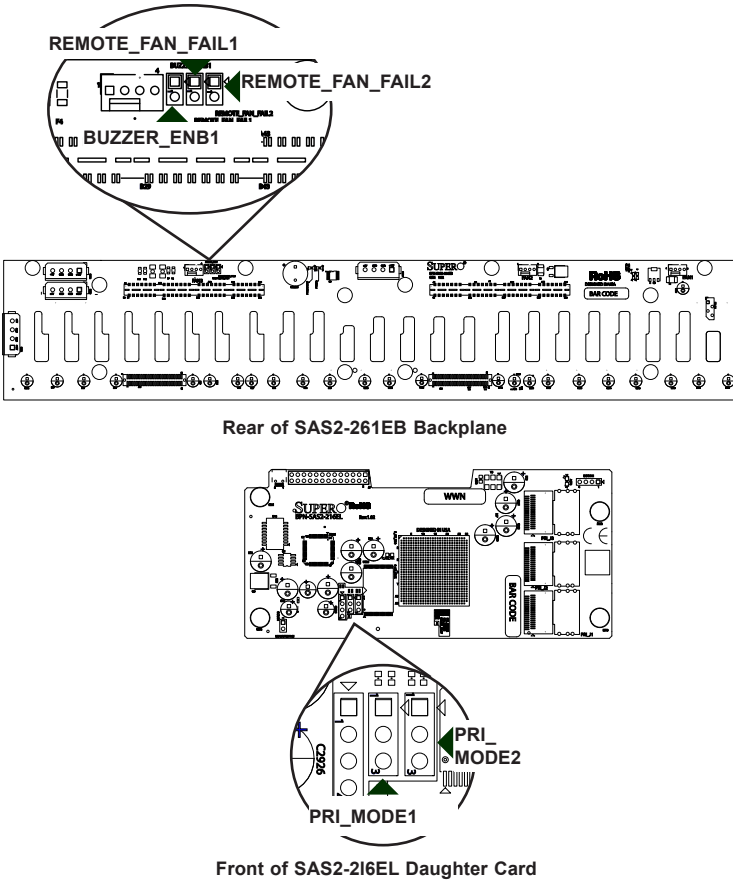
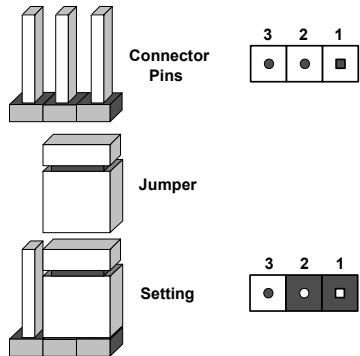

Figure C-2: Jumper Locations and Pin Definitions

Explanation of Jumpers

To modify the operation of the backplane, jumpers can be used to choose between optional settings. Jumpers create shorts between two pins to change the function of the connector. Pin 1 is identified with a square solder pad on the printed circuit board. Note: On 2-pin jumpers, "Closed" means the jumper is on and "Open" means the jumper is off the pins.



General Jumper Settings		
Jumper	Jumper Settings	Note
PRI_MODE1	Pins 2-3	Factory setting, do not change
PRI_MODE2	Pins 2-3	Factory setting do not change
REMOTE_FAN_FAIL1	Open: Enable (Default) Closed: Disable	Enables / disables the fan speed reporting.
REMOTE_FAN_FAIL2	Open: Enable (Default) Closed:Disable	Enables / disables the FANFAIL1 LED
BUZZER_ENB1	Open: Disable Closed: Enable	Buzzer enable*

*The buzzer sound indicates that a condition requiring immediate attention has occurred.

The buzzer alarm is triggered by any of the following conditions:

1. Hard drive failure
2. Fan failure
3. System temperature over 45° Celsius.

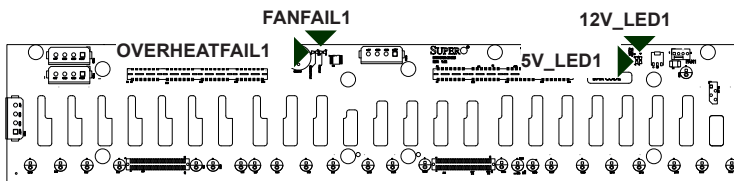

Figure C-3: Rear LEDs

Rear LEDs		
LED	Fail State	Specification
12V_LED1	Off	Green LED indicates backplane 12V power. Light is on during normal operation.
5V_LED1	Off	Blue LED indicates backplane 5V power. Light is on during normal operation.
FANFAIL1	On	Red LED indicates a fan failure. Light is off during normal operation
OVERHEATFAIL1	On	Red LED indicates an overheat condition. Light is off during normal operation

C-8 Front Connectors and LED Indicators

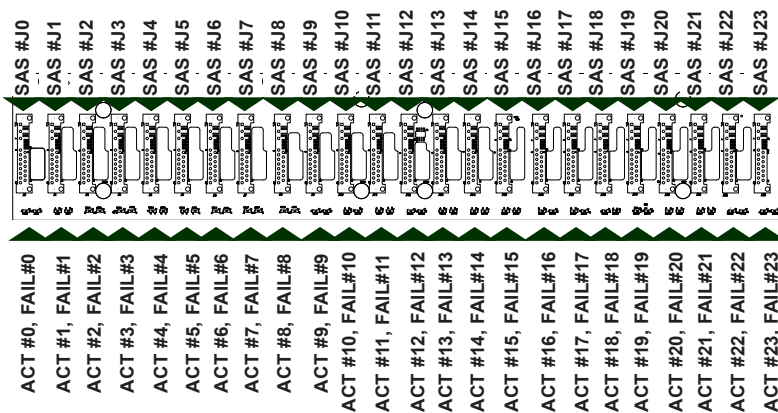

Figure C-4: Front Connectors and LEDs

Front SAS/SATA Connectors			
Front Connector	SAS Drive Number	Front Connector	SAS Drive Number
SAS #J0	SAS/SATA HDD #1	SAS #J12	SAS/SATA HDD #13
SAS #J1	SAS/SATA HDD #2	SAS #J13	SAS/SATA HDD #14
SAS #J2	SAS/SATA HDD #3	SAS #J14	SAS/SATA HDD #15
SAS #J3	SAS/SATA HDD #4	SAS #J15	SAS/SATA HDD #16
SAS #J4	SAS/SATA HDD #5	SAS #J16	SAS/SATA HDD #17
SAS #J5	SAS/SATA HDD #6	SAS #J17	SAS/SATA HDD #18
SAS #J6	SAS/SATA HDD #7	SAS #J18	SAS/SATA HDD #19
SAS #J7	SAS/SATA HDD #8	SAS #J19	SAS/SATA HDD #20
SAS #J8	SAS/SATA HDD #9	SAS #J20	SAS/SATA HDD #21
SAS #J9	SAS/SATA HDD #10	SAS #J21	SAS/SATA HDD #22
SAS #J10	SAS/SATA HDD #11	SAS #J22	SAS/SATA HDD #23
SAS #J11	SAS/SATA HDD #12	SAS #J23	SAS/SATA HDD #24

Front LED Indicators		
Front LED	Hard Drive Activity	Failure LED
SAS #J0	ACT #0	FAIL #0
SAS #J1	ACT #1	FAIL #1
SAS #J2	ACT #2	FAIL #2
SAS #J3	ACT #3	FAIL #3
SAS #J4	ACT #4	FAIL #4
SAS #J5	ACT #5	FAIL #5
SAS #J6	ACT #6	FAIL #6
SAS #J7	ACT #7	FAIL #7
SAS #J8	ACT #8	FAIL #8
SAS #J9	ACT #9	FAIL #9
SAS #J10	ACT #10	FAIL #10
SAS #J11	ACT #11	FAIL #11
SAS #J12	ACT #12	FAIL #12
SAS #J13	ACT #13	FAIL #13
SAS #J14	ACT #14	FAIL #14
SAS #J15	ACT #15	FAIL #15
SAS #J16	ACT #16	FAIL #16
SAS #J17	ACT #17	FAIL #17
SAS #J18	ACT #18	FAIL #18
SAS #J19	ACT #19	FAIL #19
SAS #J20	ACT #20	FAIL #20
SAS #J21	ACT #21	FAIL #21
SAS #J22	ACT #22	FAIL #22
SAS #J23	ACT #23	FAIL #23

C-9 Single and Dual Port Expanders

Single Ports

SAS2-216EL1 model backplanes have a single-port expander on the daughter card that accesses all of the drives and supports cascading.

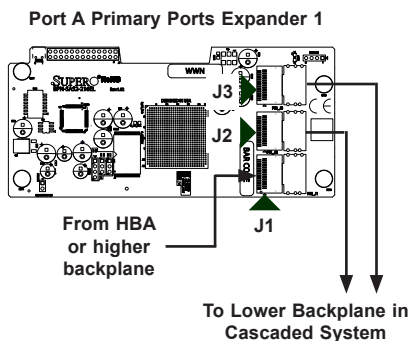

Figure C-5: SAS2-216EL1 Single Port Configuration

Dual Ports

SAS2-216EL2 model backplanes have dual-port expanders on the daughter cards that access all of the hard drives. These dual-port expanders support cascading, failover, and recovery.

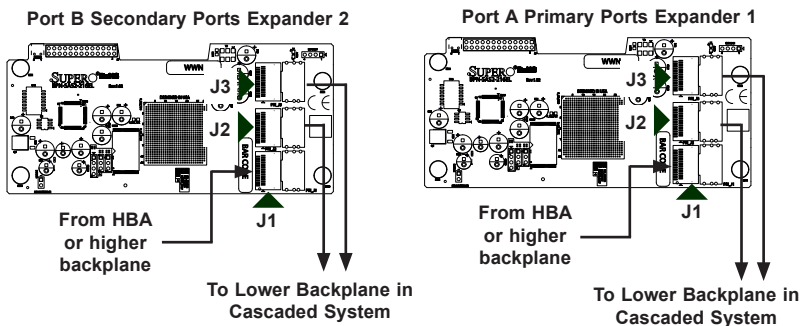

Figure C-6. SAS2-216EL2 Dual Port Configuration

C-10 Failover

The SAS2-216EL2 model backplane has two expanders which enable effective failover and recovery.

Single Host Bus Adapter

In a single host bus configuration, the backplane connects to one Host Bus Adapter (HBA).

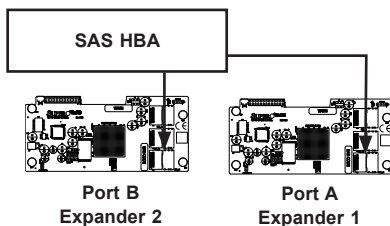

Figure E-7: Single HBA

Single Host Bus Adapter Failover

If the expander or data path in Port A fails, the system automatically switches to Port B.

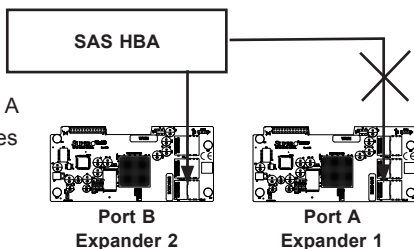

Figure E-8. Single HBA Failover

C-11 Failover with RAID Cards and Multiple HBAs

The SAS-216EL backplane may be configured for failover with multiple HBAs using either RAID controllers or HBAs to achieve failover protection.

RAID Controllers: If RAID controllers are used, then the failover is accomplished through port failover on the same RAID card.

HBAs: If multiple HBAs are used to achieve failover protection and load balancing, **Linux MPIO software must be installed and correctly configured to perform the load balancing and failover tasks.**

Dual Host Bus Adapter

In a dual host bus configuration, the backplane connects to two HBA's.

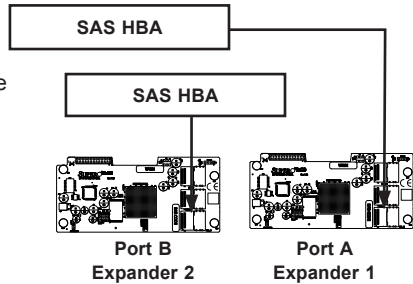

Figure C-9. Dual HBA

Dual Host Bus Adapter Failover

If the expander or data path in Port A fails, the system automatically switches to Port B. This maintains a full connection to all drives.

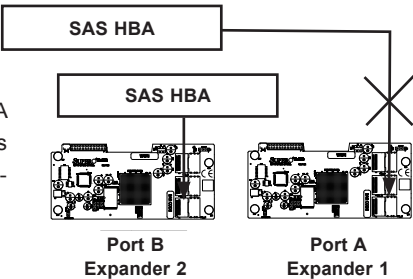

Figure C-10. Dual HBA Failover

IMPORTANT: For RAID controllers, redundancy is achieved through port failover. For multiple HBAs MPIO software is required to achieve failover protection.

C-12 Chassis Power Card and Support Cables

Chassis Power Card

In a cascaded configuration, the first chassis includes a motherboard and at least one Host Bus Adapter. Other servers in this enclosed system must be equipped with a power card. This section describes the supported power card for the SAS2-216EL series backplane.

For more information, see the Supermicro Web site at <http://www.supermicro.com>.

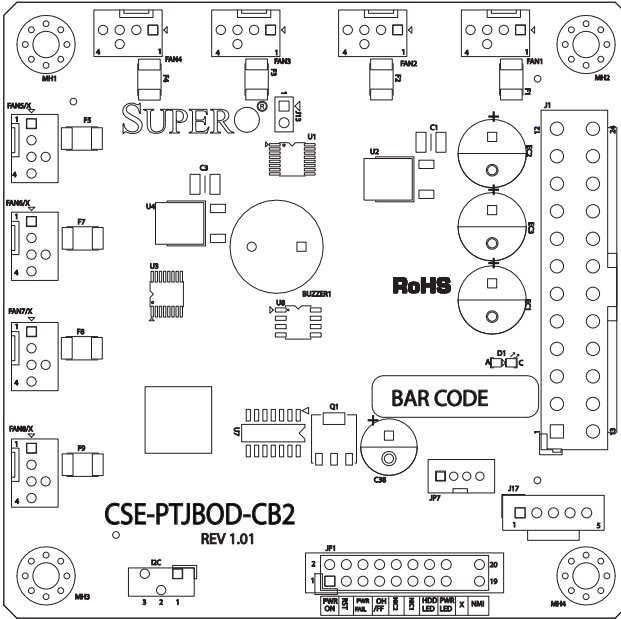

Figure C-11. Chassis Power Card (Sold Separately)

Power Card		
Part Number	Part Type	Where Used
CSE-PTJBOD-CB2	Power Card	Allows the chassis to be used as a JBOD (Just a Bunch of Drives) system.

Connecting an Internal HBA to the Backplane

The following section lists the most common cables used to connect the HBA to the backplane.

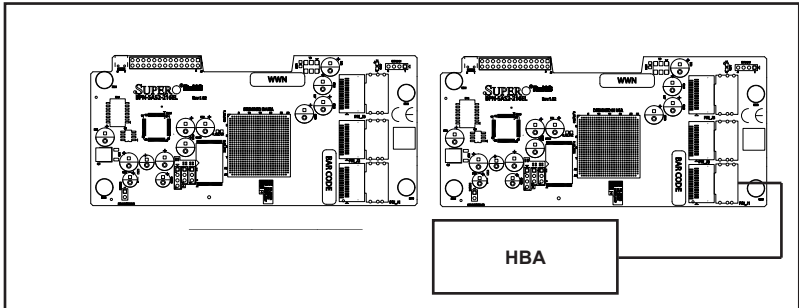

Figure C-12. Single Internal Host Bus Adapter

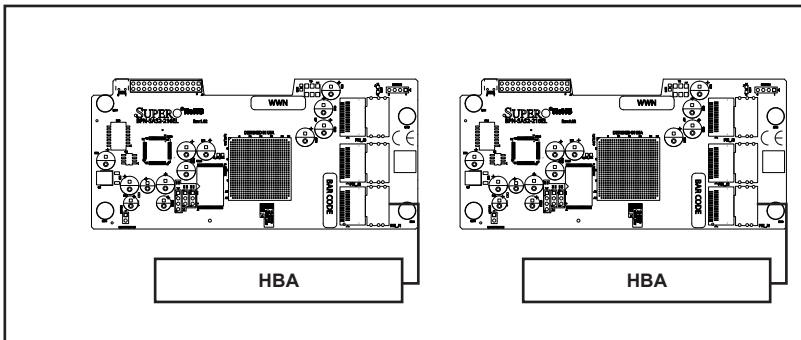

Figure C-13. Dual Internal Host Bus Adapter

Supported Internal HBA Cables

Use the following cables to create connections between the internal HBA and SAS2-216EL model backplane. The cables required depend upon the HBA connector.

Cable Name: iPass to 4-Lane

Part #: CBL-0117L

Length: 46 cm (18 inches)

Description: This cable has one SFF-8484 (32-pin) connector at one end and one iPass (SFF-8087/Mini-SAS) connector (36-pin) at the other. This cable connects from the HBA to the SAS2-216EL backplane

IMPORTANT: See Section C-11 of this manual, *Failover with RAID Cards and Multiple HBAs* for important information on supported configurations.

Connecting an External HBA to the Backplane

This backplane supports external host bus adapters. In this configuration, the HBA and the backplane are in different physical chassis. This allows a JBOD (Just a Bunch Of Drives) configuration from an existing system.

Single External Host Bus Adapter

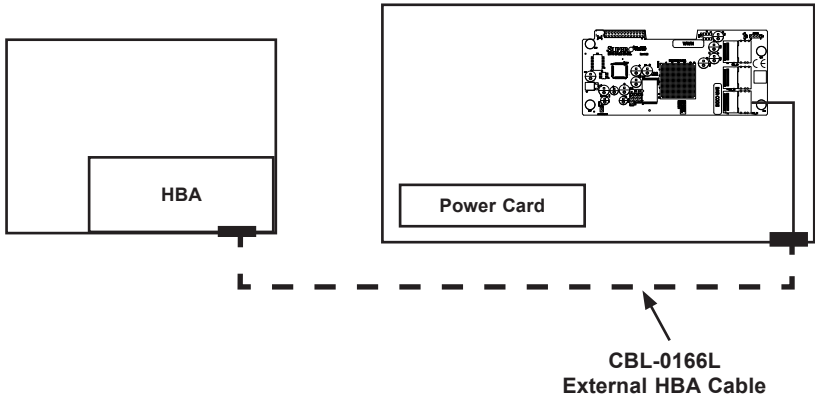

Figure C-14. Single External Host Adapter

Dual External Host Bus Adapter

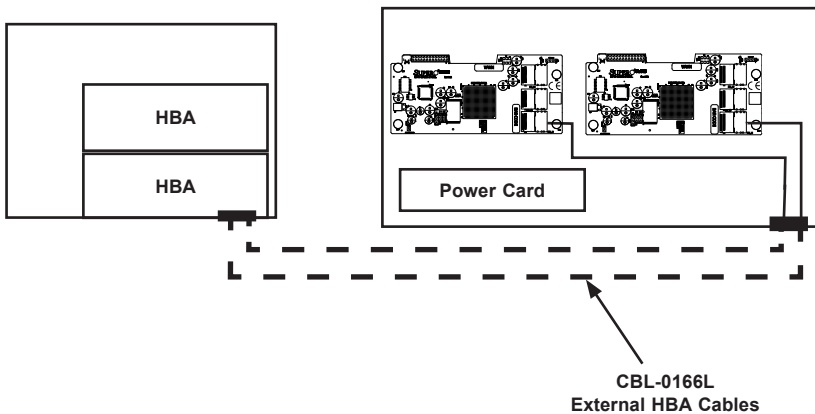

Figure E-15. Dual External Host Bus Adapter

IMPORTANT: See Section C-11 of this manual, *Failover with RAID Cards and Multiple HBAs* for important information on supported configurations.

Supported External HBA to Backplane Cable

Use the following cable if your external HBA has an InfiniBand connector.



Figure C-16. SAS InfiniBand Cable (CBL-0200L)

Cable Name: SAS InfiniBand to Mini-SAS X4 1M cable, PBF

Part #: CBL-0200L

Length: 1 meter

Description: This cable has an InfiniBand connector (SFF-8470) on one end and an SFF-8088-1X (26-pin) connector at the other end.

Connecting Multiple Backplanes in a Single Channel Environment

This section describes the cables used when cascading from a single HBA. These connections use CBL-0167L internal cables and CBL-0166L external cables.

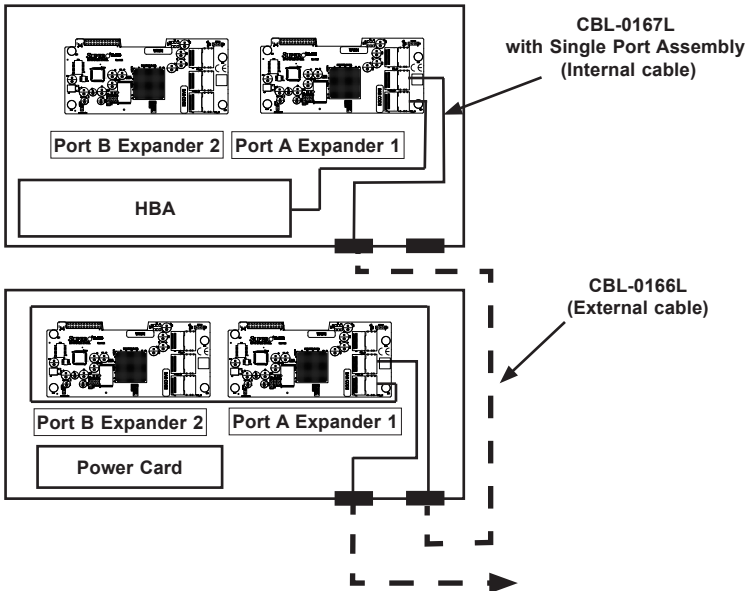

Figure C-17: Single HBA Configuration

Single HBA Configuration Cables

Single Port Cable Assembly

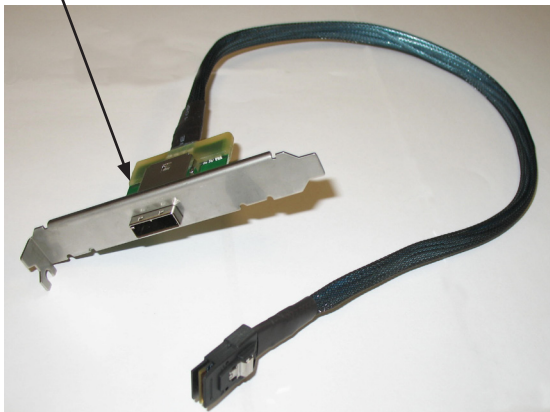

Figure C-18. Single Port Internal Cable (CBL-0167L)

Cable Name: SAS EL2/EL1 Backplane Cable (internal) with 2-port Cascading Cable, 68 cm

Part #: CBL-0167L (SFF-8087 to SFF-8088 x1)

Ports: Single

Placement: Internal cable

Description: Internal cable. Connects the backplane to the HBA or external port. Used in single port environments



Figure E-19. External Cable (CBL-0166L)

Cable Name: SAS EL2/EL1 Cascading Cable (External), 68 cm

Part #: CBL-0166L (SFF-8088 1x to SFF-8088 x1)

Ports: Single or Dual

Placement: External cable

Description: External cascading cable. Connects ports between servers. With most connectors, use one cable for single port connections and two cables for dual port connections.

Connecting Multiple Backplanes in a Dual Channel Environment

This section describes the cables used when cascading from dual HBAs. These connections use CBL-0168L internal cables and CBL-0166L external cables.

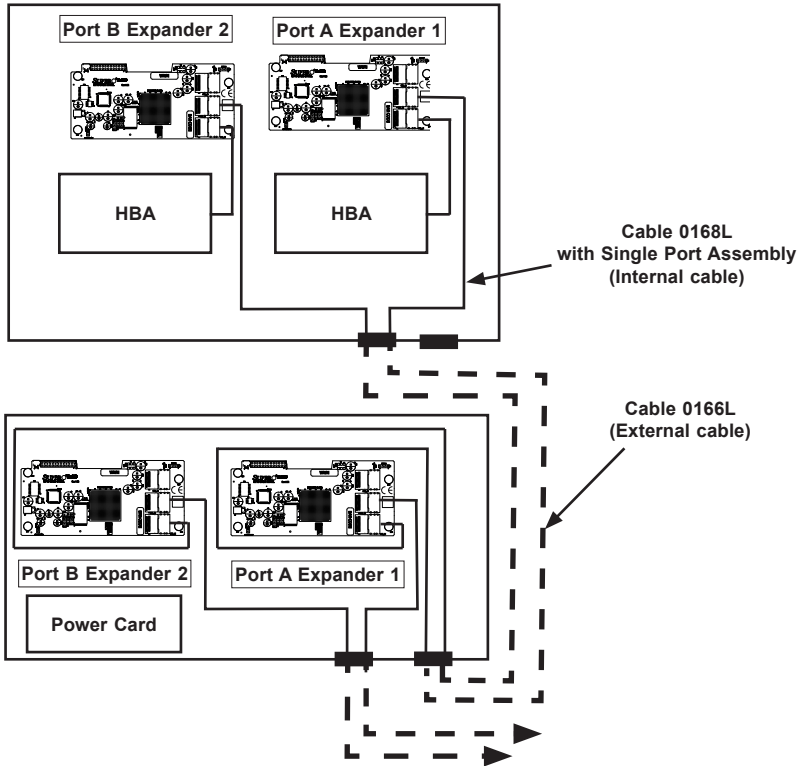

Figure C-20. Dual HBA Configuration

IMPORTANT: See Section C-11 of this manual, *Failover with RAID Cards and Multiple HBAs* for important information on supported configurations.

Dual HBA Configuration Cables

Dual Port Cable
Assembly



Figure C-21. Dual Port Internal Cable (CBL-0168L)

Cable Name: SAS Dual-port Cable Assembly, 68/76 cm

Part #: CBL-0168L

Placement: Internal cable

Ports: Dual

Description: Internal cascading cable. Connects the backplane to the host bus adapter or external port. Used in dual port environments.



Figure C-22. External Cable (CBL-0166L)

Cable Name: SAS EL2/EL1 Cascading Cable (External), 68 cm

Part #: CBL-0166L

Placement: External Cable

Ports: Single or Dual

Description: External cascading cable. Connects ports between servers. Use one cable for single port connections and two cables for dual port connections.

C-13 Supported Cascading Configurations

Cascading allows the system to access data at a faster rate by allowing several backplanes to share resources to reduce latency time.

The first backplane in a cascaded system requires a motherboard and an HBA. Other servers require a power control card with no motherboard and no HBA. For more information, specific chassis manuals are available at www.supermicro.com.

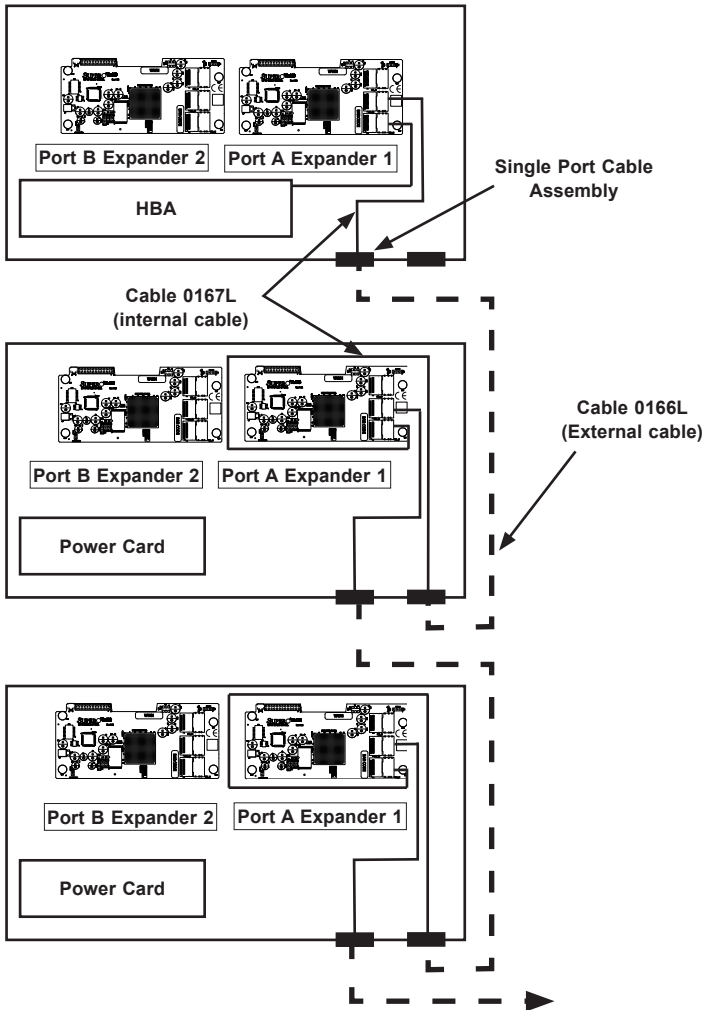

Figure C-23. Simple Cascaded Configuration

Server System with Single SAS HBA

The expanders allow horizontal branching. This configuration also applies to dual ports.

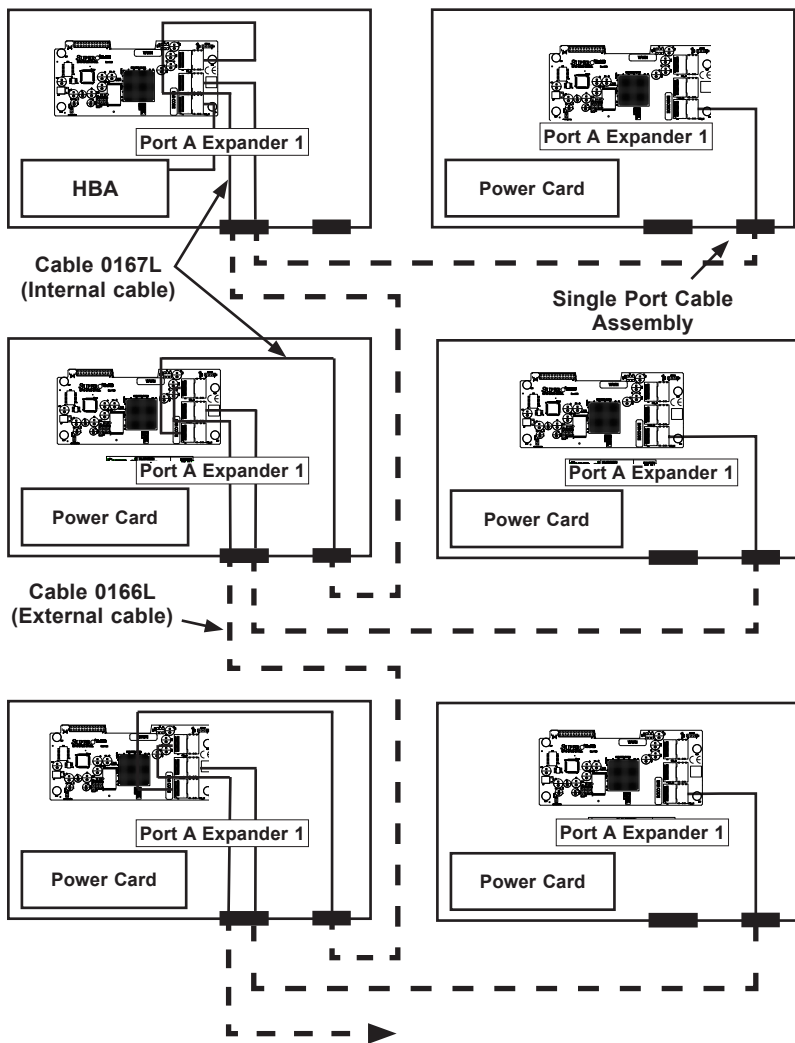

Figure C-24. Cascaded Configuration with Horizontal Branching

Dual SAS HBA and Cascaded Configuration

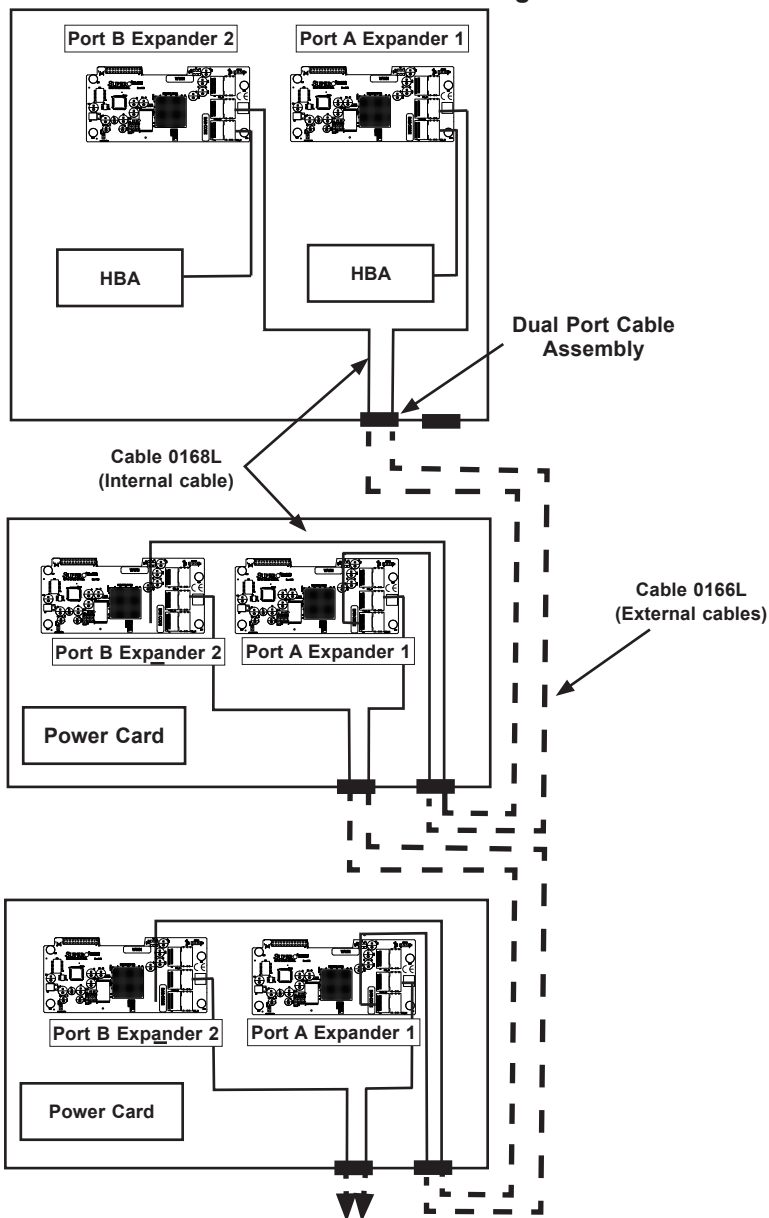

Figure C-25. Dual SAS HBA with Cascaded Configuration

IMPORTANT: See Section C-11 of this manual, *Failover with RAID Cards and Multiple HBAs* for important information on supported configurations.

Dual SAS HBA and Cascaded Configuration with Branching

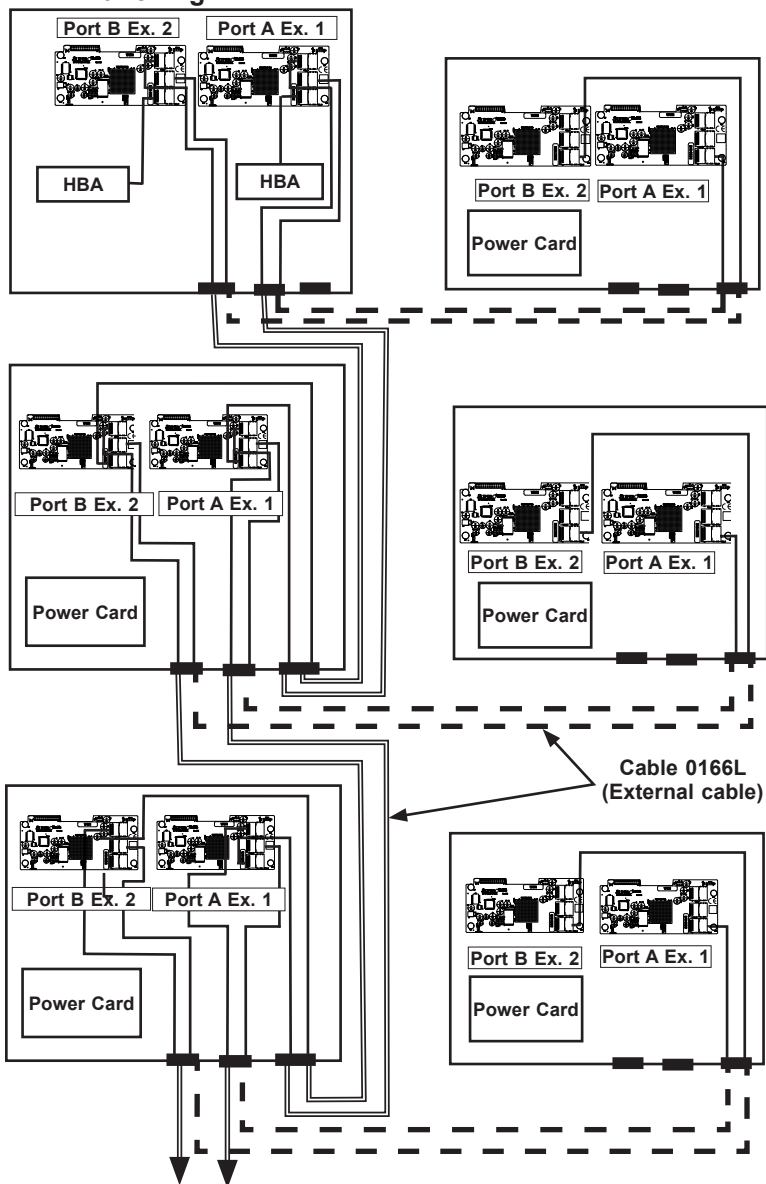

Figure E-26. Dual SAS HBA Cascaded Configuration and Branching

IMPORTANT: See Section C-11 of this manual, *Failover with RAID Cards and Multiple HBAs* for important information on supported configurations.

Notes

Disclaimer (cont.)

The products sold by Supermicro are not intended for and will not be used in life support systems, medical equipment, nuclear facilities or systems, aircraft, aircraft devices, aircraft/emergency communication devices or other critical systems whose failure to perform be reasonably expected to result in significant injury or loss of life or catastrophic property damage. Accordingly, Supermicro disclaims any and all liability, and should buyer use or sell such products for use in such ultra-hazardous applications, it does so entirely at its own risk. Furthermore, buyer agrees to fully indemnify, defend and hold Supermicro harmless for and against any and all claims, demands, actions, litigation, and proceedings of any kind arising out of or related to such ultra-hazardous use or sale.